



Water Powered Oscillating Monitor Stations

The Chemguard Water Powered Oscillating Monitor Station is a self-contained unit that relies only on water flow and pressure to place the system into operation. It is designed to be installed in an aircraft hangar for under-wing protection. It has a tank capacity from 100–300 gallons of foam concentrate, oscillating monitor and a 500 gpm self-educing nozzle. All that is required to place the unit in operation is to fill the foam concentrate storage tank with the correct type and quantity of foam concentrate and connect a suitable water source to the inlet.

FEATURES

- Nozzle is a self-educing, non air-aspirating type, which has a better stream and gives a constant flow whether on straight stream or fog patterns. Nozzle flow rate is 350, 500, 750 or 1000 gpm @ 100 psi.
- Foam concentrate storage tank is manufactured of type 316 stainless steel.
- Pick-up tube has manual ball valve that can be closed to be used with water only.
- Tank is supplied with 1" drain plug and 4" fill opening on top of tank.
- Tank can be refilled during operation of the unit.
- Suitable for use with any type foam concentrate.

OPTIONS

- Other size self-educing nozzle selections available.
- Five different tank capacities available

CAUTION

If the unit is to be used with any of the AR-AFFF type foam concentrates, it is recommended that a thin layer of mineral oil be placed on the surface of the concentrate to minimize evaporation.

RESERVE CAPACITY OPTION (NFPA 409)

Each unit can be ordered with a pre-piped 100% reserve capacity to meet the requirements of NFPA 409 – Standard on Aircraft Hangars.



CHEMGUARD
204 S. 6th Ave • Mansfield, Tx 76063 • (817) 473-9964 • FAX (817) 473-0606
www.chemguard.com

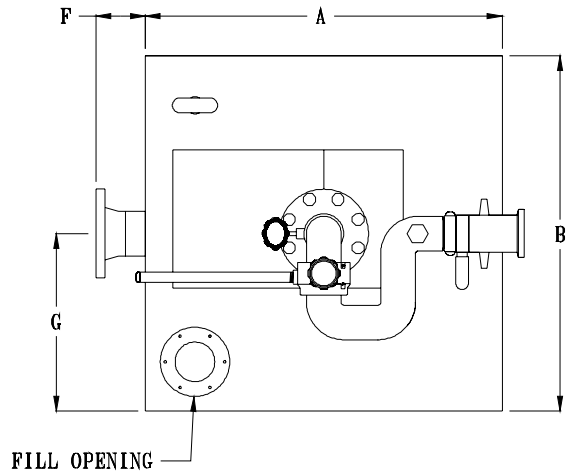

TANK SIZE GALLONS	DIMENSIONS, INCHES						
	A	B	C	D	E	F	G
100	48	24	30.0	51	18.0	5	12
125	48	24	30.0	51	18.0	5	12
150	48	32	30.0	51	18.0	5	16
200	48	48	30.0	51	18.0	5	24
300	48	48	34.0	55	18.0	5	24

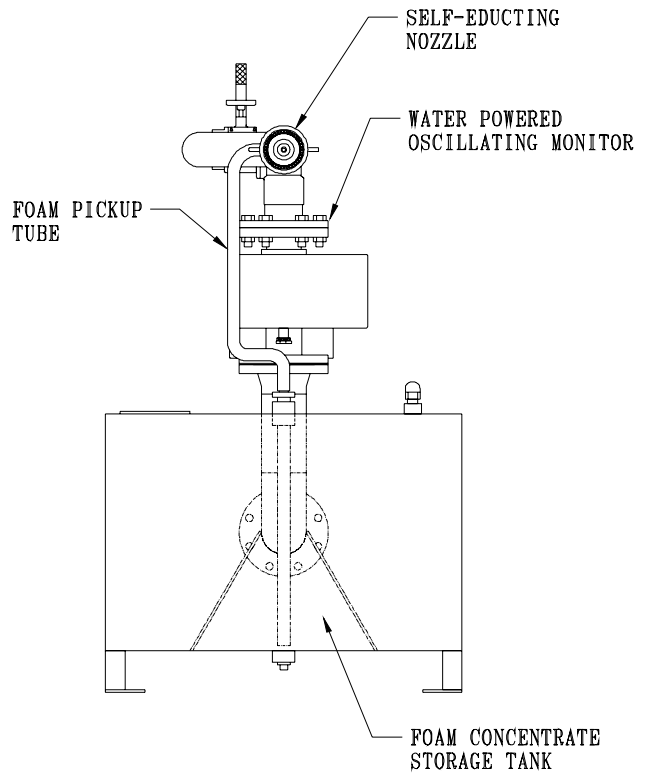
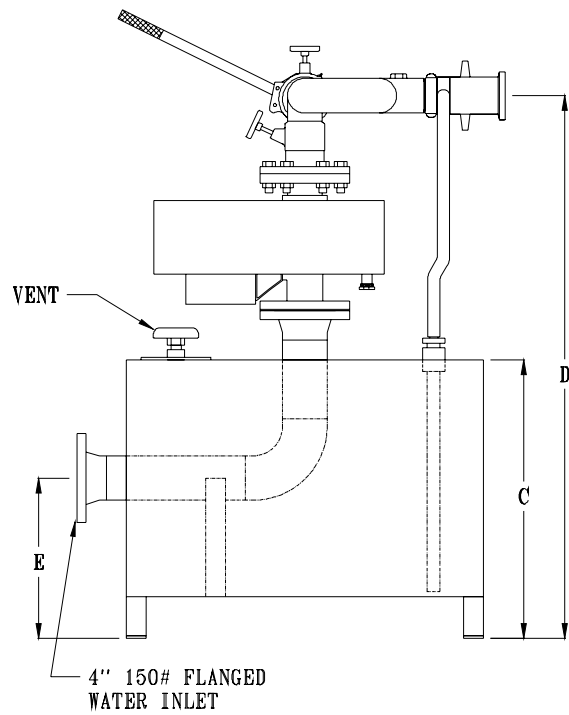

CHEMGUARD
 204 S. 6th Ave • Mansfield, Tx 76063 • (817) 473-9964 • FAX (817) 473-0606
www.chemguard.com