

Product Drying

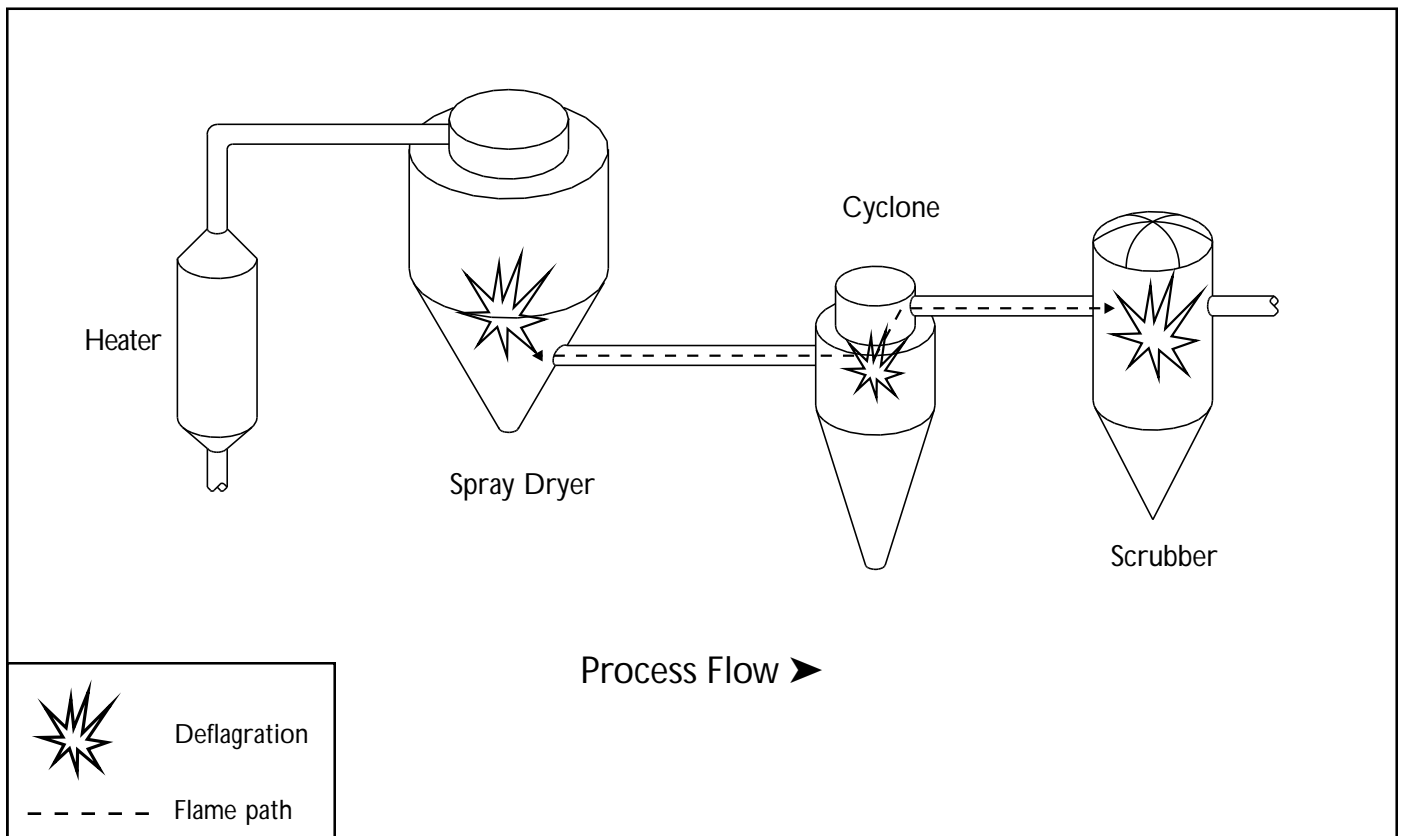

Figure 1: Unprotected Product Drying System

INTRODUCTION

In the production of powdered food or pharmaceutical products, one process step involves drying the product. This is commonly done by a fluid bed or spray dryer. Inherent to this process is the requirement to suspend the powder in air. The suspended powder may create a dangerous potential for an explosion and in cases where a flammable solvent or gas is present with the powder (hybrid mixture) this explosion potential is magnified.

The purpose of this application guide is to provide an understanding of the possible hazards and protection solutions utilizing a Fike Explosion Isolation Valve system. This document is intended to be used as a guideline and is not applicable to all situations. If you have any questions, please contact the Fike Explosion Protection Group or our sales representative in your area.

THE HAZARD: FLAME PROPAGATION

The drying process can involve the use of heaters to preheat inlet air, bag filters or cyclones to clean the exhaust air, and many feet of ducting and fans to transport the product through the process. (See figure 1) Even if the dryer is designed and protected (with explosion venting or pressure containment, for example) against a possible explosion, there is the hazard of flame propagation to interconnected vessels that are not explosion protected.

If flame is allowed to propagate to interconnected vessels, it can lead to “pressure piling”, where the pressure is built up in the adjoining vessel prior to the flame arriving. The ensuing deflagration in this connected vessel now starts at an increased pressure with correspondingly more serious consequences, both in terms of the rate of combustion and final pressure.

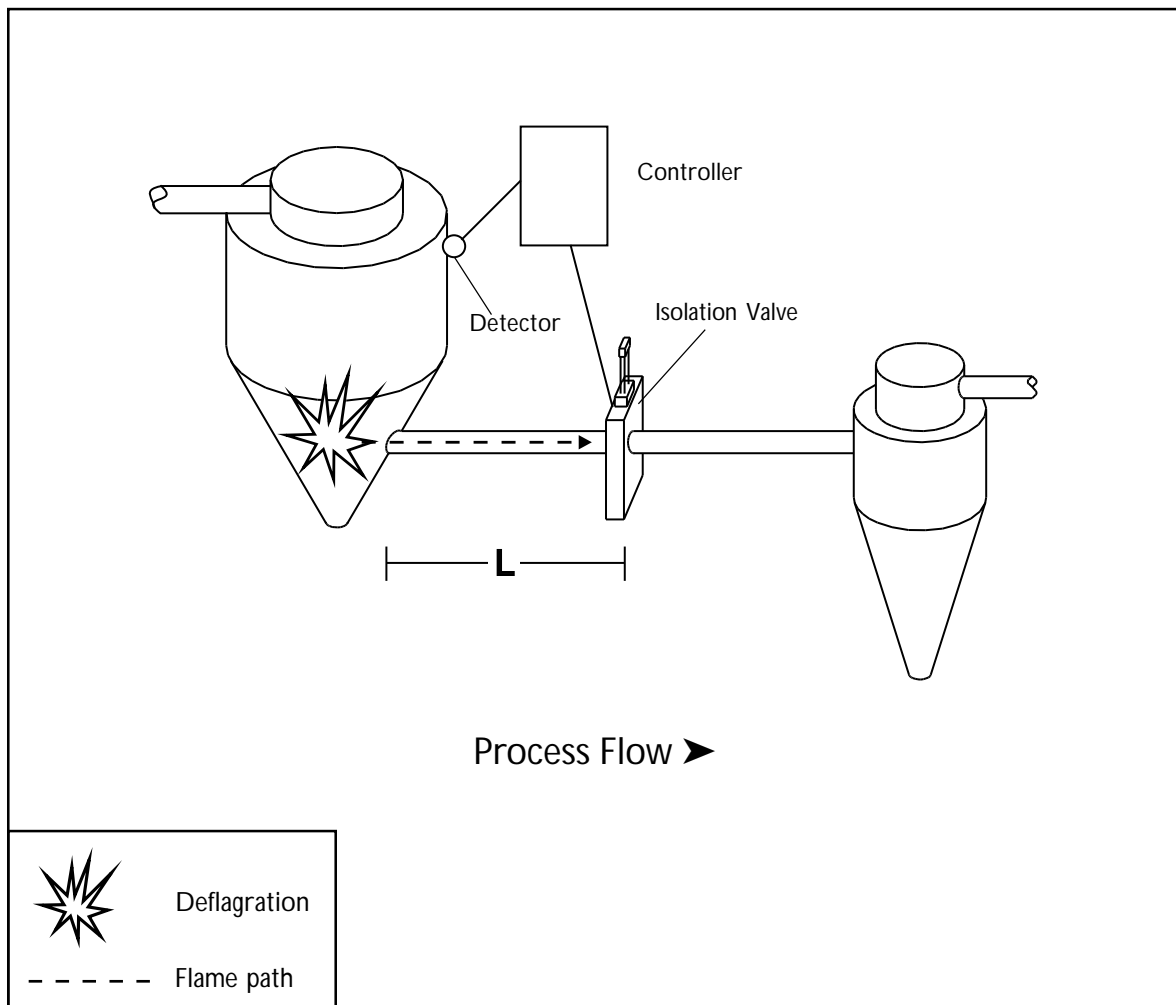

Figure 2: Typical engineered system component placement

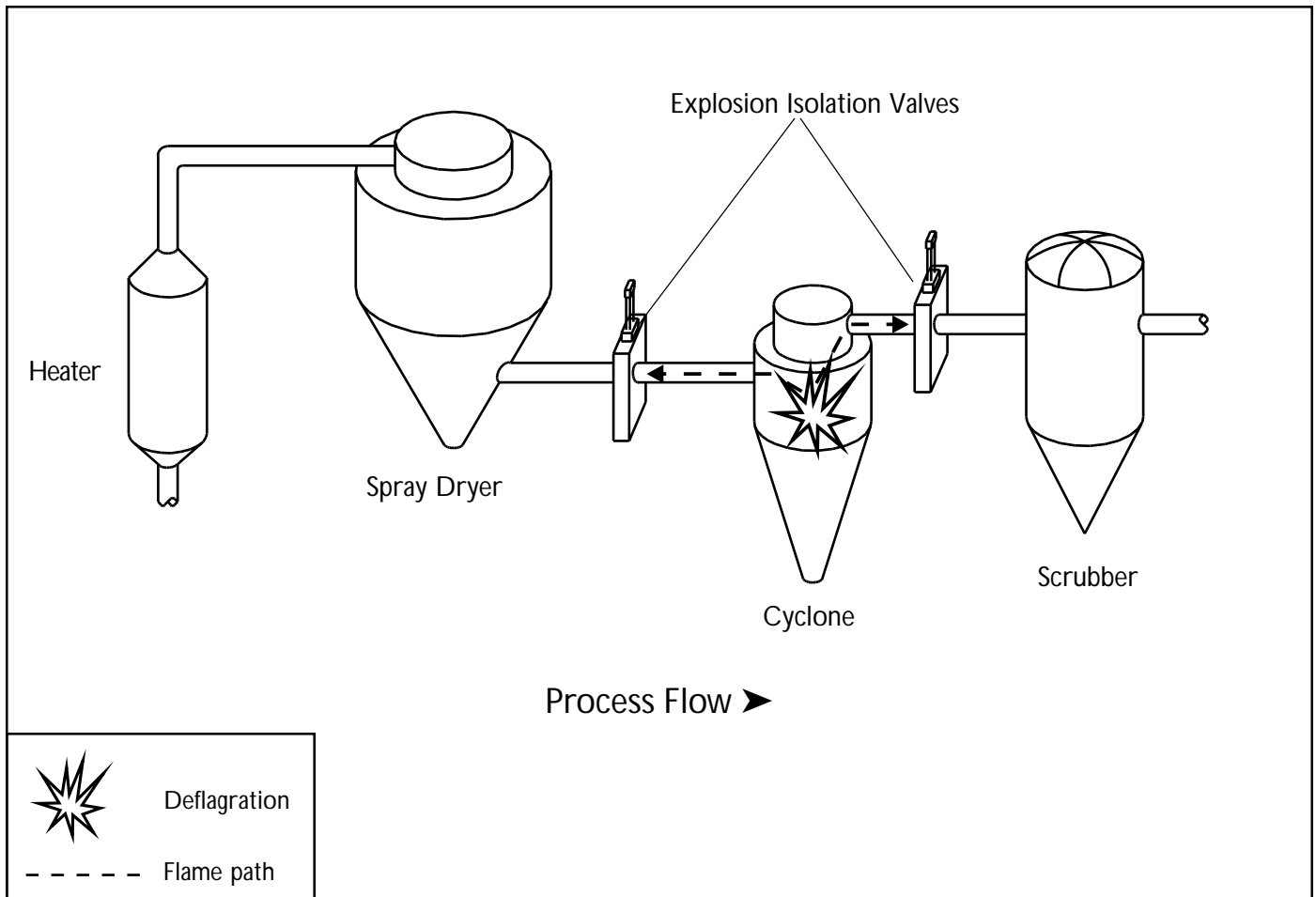

Figure 3: Protected Product Drying System

THE SOLUTION: EXPLOSION ISOLATION

NFPA 68 states that deflagration isolation devices should be considered when separate pieces of equipment are interconnected.

The Fike Explosion Isolation Valve System will prevent flame propagation without compromising normal process operations. The fast-acting valve closes within milliseconds of deflagration detection.

Some advantages of the Fike Explosion Isolation Valve compared to other possible isolation solutions are:

- minimal distance required from ignition point. (See Figure 2)
- new *bidirectional* design can stop flame originating from either side of the valve, eliminating the need for two isolation devices.
- full port valve opening provides no pressure drop across the valve.
- applications include flammable vapors, gasses, dusts, and hybrid mixtures (dust/gas).
- valve assembly can be mounted on both horizontal and vertical piping.
- new conduit valve design provides a “clean” valve seat.
- the Fike Explosion Isolation System has been designed and tested to be compatible with CIP (Clean In Place) processes.
- easily serviced.

SAMPLE PARTS LIST

The following is a sample parts list for a typical application, which would require one isolation zone. Please consult with Fike or the sales representative in your area for your particular application.

QTY	PART NUMBER	DESCRIPTION
1	E10-008-10	System Controller, NEMA 4X Enc.
3	E02-0081	Caution Sign
1	20-051	Alarm Horn
1	20-1047	Alarm Horn Box, weather proof
1	E61-003	Pressure Detector, Haz SST/Vac supprt
1	E30-005	Explosion Isolation Valve, Conduit
1	E85-002	Reload Kit, 1"
1	E02-0036	Fill Valve Tool

COMPLETE PROTECTION SERVICES

- Explosion Venting
- Explosion Suppression Systems
- Explosion Testing Services

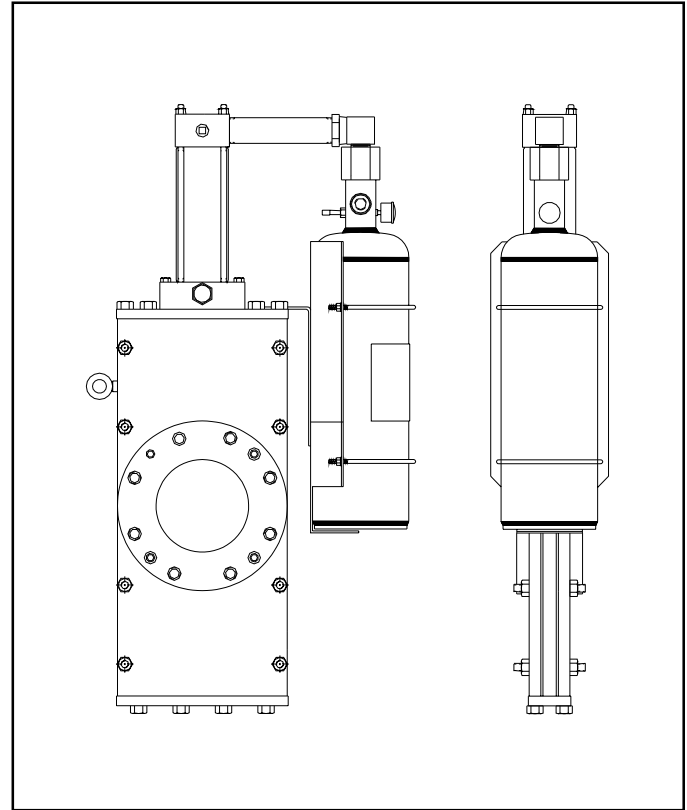

Explosion Isolation Valve: Front and side views

Fike[®]
Metal Products
Division Fike Corporation

704 South 10th Street • P.O. Box 610 • Blue Springs, Missouri 64015
Phone (816) 229-3405 • Telefax (816) 228-9277