

Vapor Recovery System

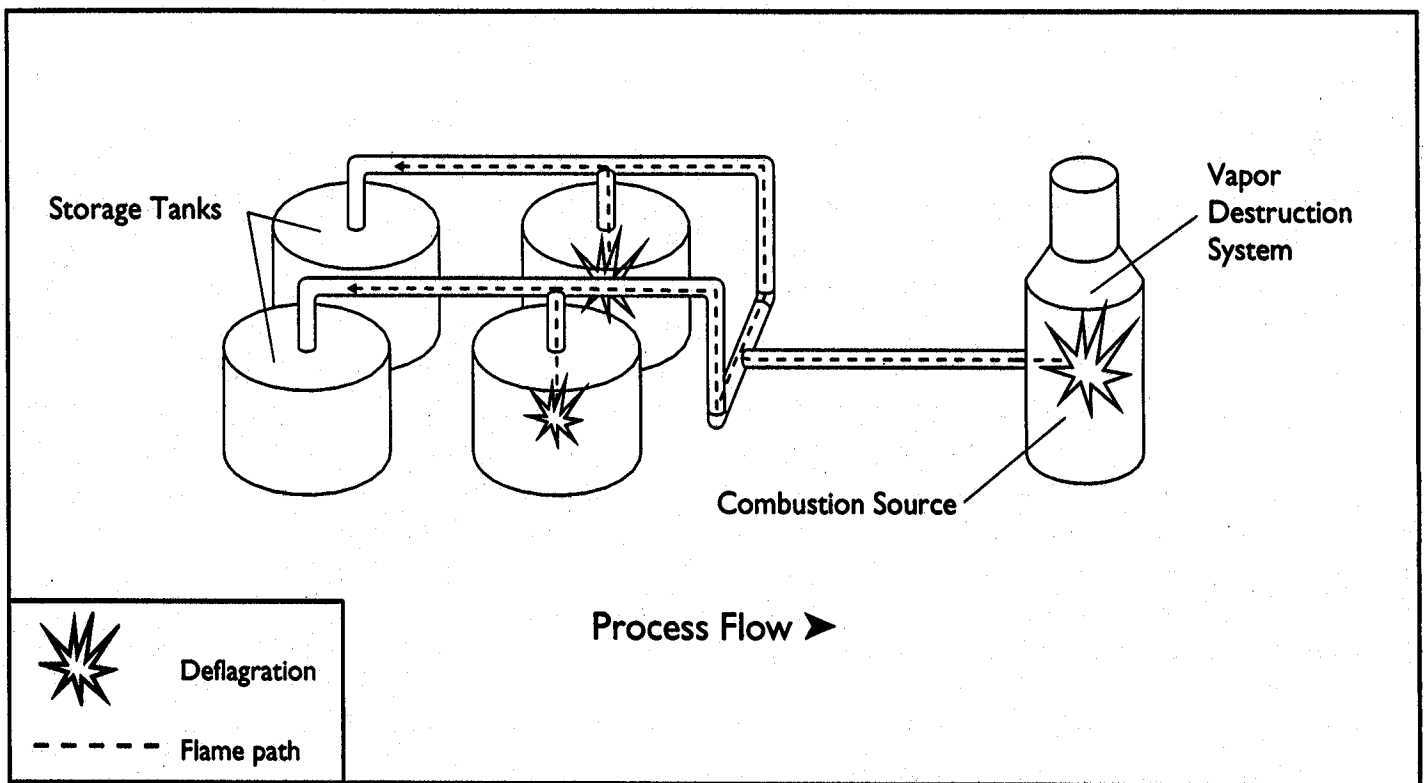

Figure 1: Unprotected Vapor Collection System

INTRODUCTION

The enactment of the Clean Air Act has placed an increasing focus on the need to recover and/or destroy vapor emissions. This requirement has led to the development of closed vapor collection or destruction systems where volatile gases or vapors are collected and transported to some type of processing equipment, i.e. thermal oxidizer, flare, boiler, condenser, etc. These vapor collection systems help safeguard the environment, but can also create a dangerous potential for fire and explosion. (See Figure 1)

The purpose of this application guide is to provide an understanding of the possible hazards and protection solutions utilizing a Fike Explosion Isolation Valve system. This document is intended to be used as a guideline and is not applicable to all situations. If you have any questions, please contact the Fike Explosion Protection Group or our sales representative in your area.

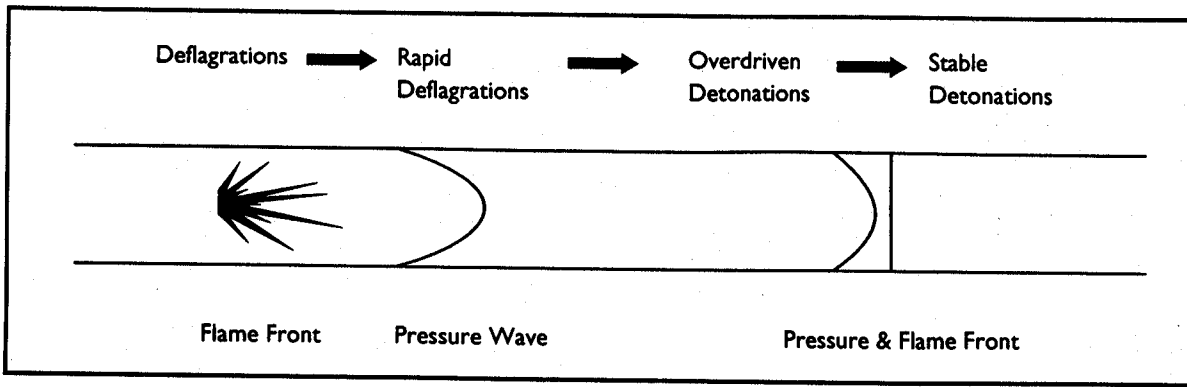

Figure 2: Explosion Phenomena In Pipes

THE HAZARD: FLAME PROPAGATION

The initial collection point of the volatile gases/vapors may be anywhere from a process vessel emergency relief system to tank farm venting. These systems now require manifolds that create a number of safety hazards that were not encountered with “stand-alone” processes. The piping runs in manifolded systems tend to be of greater length and complexity.

It is important to understand how flames propagate through closed piping or manifolded tank storage systems. Upon ignition, the flame generates a pressure wave. Initially the pressure wave is traveling much faster than the flame front. This is known as deflagration phenomena. The flame front propagates into the unburned fuel mixture, **even against normal process flow**, at less than the speed

of sound. At the same time, the pressure wave travels ahead of the flame at the speed of sound. Factors such as turbulence and increased flame surface area cause the rapid acceleration of the flame front. (See Figure 2)

In addition to the hazards of detonations, if flame is allowed to propagate to interconnected vessels, it can lead to “pressure piling”, where the pressure is built up in the adjoining vessel prior to the flame arriving. The ensuing deflagration in this connected vessel now starts at an increased pressure with correspondingly more serious consequences, both in terms of the rate of combustion and final pressure.

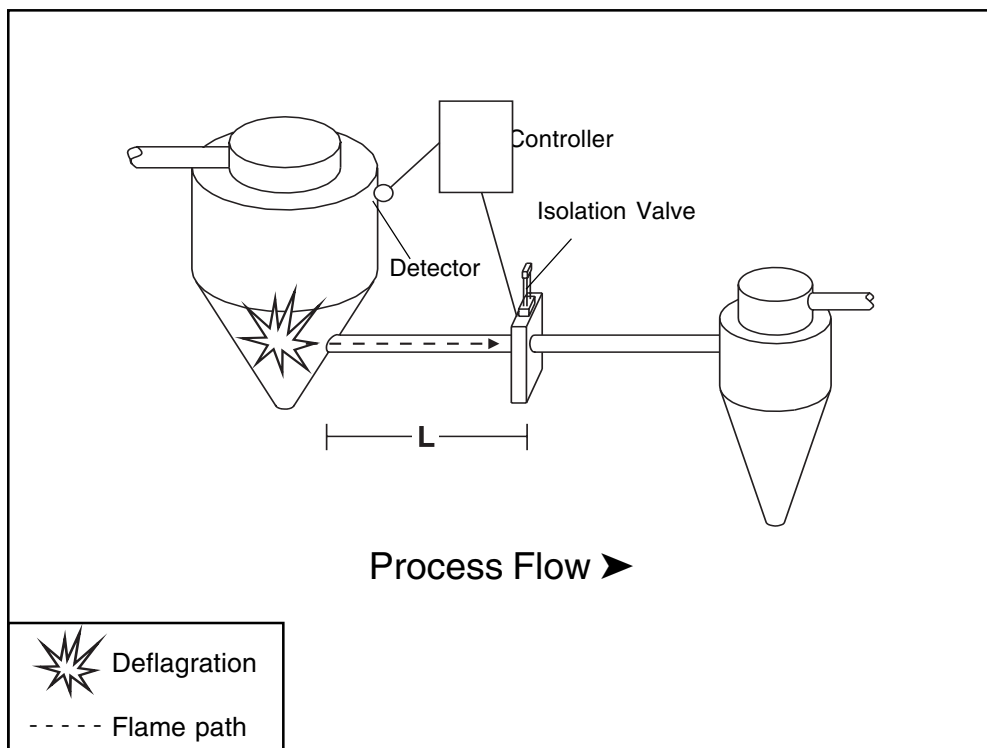

Figure 3: Typical engineered system component placement

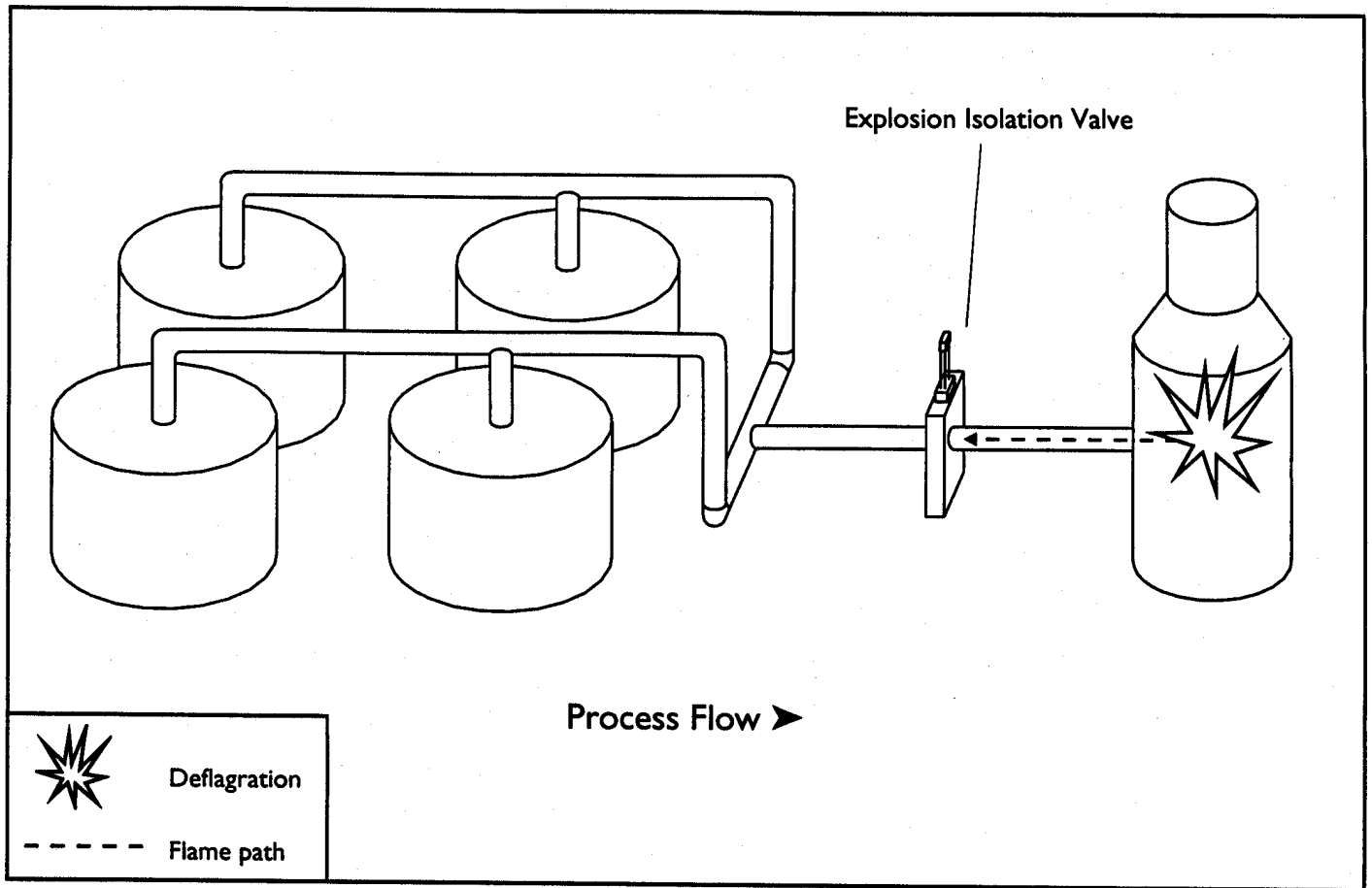

Figure 4: Protected Vapor Recovery System

THE SOLUTION: EXPLOSION ISOLATION

NFPA 68 states that deflagration isolation devices should be considered when separate pieces of equipment are interconnected.

The Fike Explosion Isolation Valve System will prevent flame propagation without compromising normal process operations. The fast-acting valve closes within milliseconds of deflagration detection.

Some advantages of the Fike Explosion Isolation Valve compared to other possible isolation solutions are:

- minimal distance required from ignition point. (See Figure 3)
- new *bidirectional* design can stop flame originating from either side of the valve, eliminating the need for two isolation devices.
- full port valve opening provides no pressure drop across the valve.
- applications include flammable vapors, gasses, dusts, and hybrid mixtures (dust/gas).
- valve assembly can be mounted on both horizontal and vertical piping.
- new conduit valve design provides a “clean” valve seat.
- easily serviced.

SAMPLE PARTS LIST

The following is a sample parts list for a typical application, which would require one isolation zone. Please consult with Fike or the sales representative in your area for your particular application.

QTY	PART NUMBER	DESCRIPTION
1	E10-008-10	System Controller, NEMA 4X Enc.
3	E02-0081	Caution Sign
1	20-051	Alarm Horn
1	20-1047	Alarm Horn Box, weather proof
1	E61-003	Pressure Detector, Haz SST/Vac supprt
1	E30-005	Explosion Isolation Valve, Conduit
1	E85-002	Reload Kit, 1"
1	E02-0036	Fill Valve Tool

COMPLETE PROTECTION SERVICES

- Explosion Venting
- Explosion Suppression Systems
- Explosion Testing Services

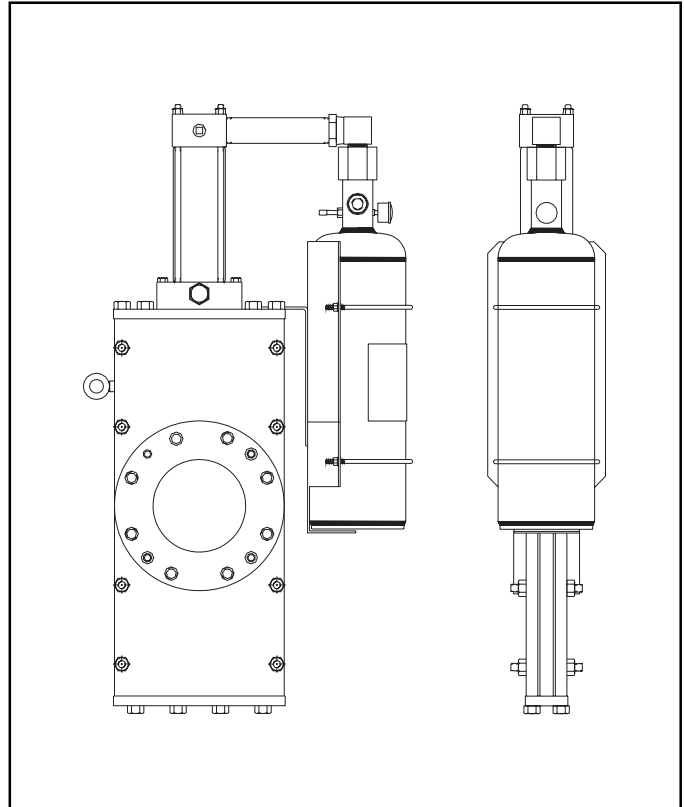

Explosion Isolation Valve: Front and side views



704 South 10th Street • P.O. Box 610 • Blue Springs, Missouri 64015
Phone (816) 229-3405 • Fax (816) 229-0314