



Machinery Spaces are hazards whose main source of potential Class B flammable or combustible liquids used in various processes or pumps. Examples of machinery spaces include test cells for internal combustion engines fueled by gasoline or diesel fuel, electrocoating, dipping or cleaning processes using flammable liquids, pumps, piping, or containers under pressure that might be used for hydraulic pumping equipment, drive generators or chemical processes.

In summary, machinery space hazards are areas that contain liquid processing hazards with Class 1, 2, or 3 flammable liquids as specified in NFPA 325 and certain Class A combustibles. The Fike Micromist Water Mist Extinguishing System has successfully demonstrated extinguishment in Factory Mutual fire tests for machinery spaces up to 9,175 (260 m³).

The purpose of this application profile is to provide an understanding of the possible hazards associated with machinery spaces and protection solutions utilizing the Fike Micromist Water Mist Extinguishing System. This document is intended to be a guideline and is not applicable in all situations. Fike's Micromist Design, Installation, and Maintenance Manual and NFPA 750 shall be referred to when designing Micromist systems. If you have any questions, please contact the Fike Protection Systems group, or our regional sales manager in your area.

Machinery Spaces typically have open and/or forced ventilation keeping the areas cool during operation. These areas may also contain obstructions where fires may likely occur. The Fike Micromist system is very effective when handling shielded fires and in most cases extra nozzles are not needed behind obstructions. Although the Fike Micromist system is very flexible when dealing with ventilation, it is good fire protection practice to shut down all ventilation and close all openings before a system discharge. Dampers for ventilation are not required when using a Micromist system. The hazard associated within most machinery space applications is identified as the ignition of Class B fuels in the following configurations:



- Pools of fuel leakage on equipment surfaces and/or the floor of the enclosure
- Fuel sprays due to a rupture of pressurized pipes
- Potential Class A involvement caused by ignition of fuel soaked materials

The Fike Micromist system has successfully passed the Factory Mutual fire test protocol for machinery spaces and compartmentalized gas turbine generators. The system will very effectively suppress flammable liquid pool fires as well as spray fires, which could ignite from a ruptured hose or pipe in a process using flammable liquids.

THE SOLUTION: TOTAL COMPARTMENT PROTECTION

Total compartment protection is implemented when protecting machinery space applications. The Micromist systems are offered in 70 and 107 gallon (265 and 405 liter) configurations. Each system package is skid-mounted and includes all necessary valves and actuation components for system operation. System nozzles, with a maximum flow rate of 2.1 gal./min (8 liters/min) of water at 310 psi (21Bar), are ceiling mounted. Nozzles shall be installed away from structures, ductwork, or other permanent equipment that may lead to discharge interference. Each Micromist system package is pre-assembled and tested to ensure system reliability and simplify installation.

The nozzle arrangement for a machinery space requires spacing the nozzles on a maximum of 8' (2.4m) centers and a maximum of 4' (1.2m) from the walls. An area 24' x 24' x 16' (7.3m x 7.3m x 4.9m) high would have nine (9) nozzles equally spaced on 8' (2.4m) centers at the ceiling. The piping arrangement is shown in the figure below. Refer to the Micromist Design, Installation & Maintenance Manual for a detailed description of nozzle spacing and piping requirements.

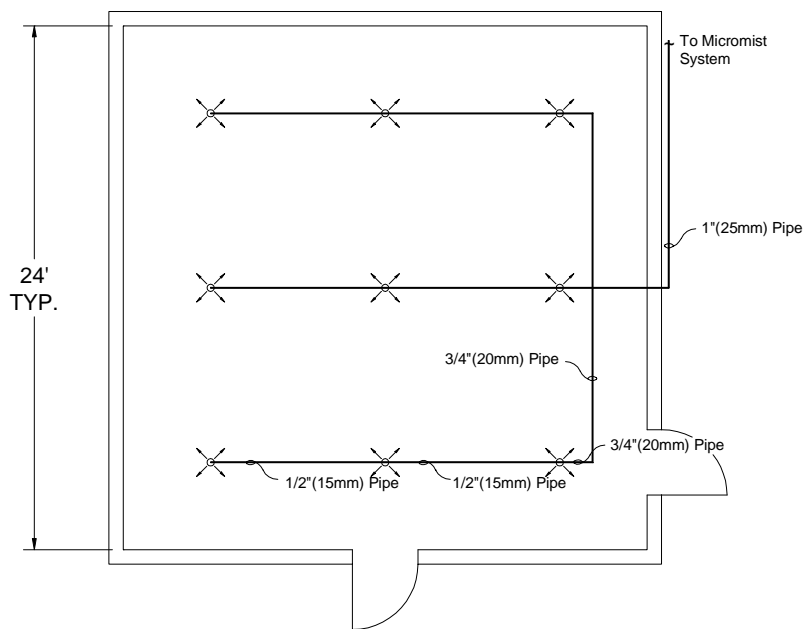

Typical Piping Layout
Machinery Space

The Micromist system equipment shall be stored at a temperature range of 40° to 130° F (4.4° to 54° C). The Micromist System can be used to protect hazards that range in temperature from 40° to 325°+ F (4.4° to 162.7° C).

Water mist is a desirable agent for use in protection of machinery space enclosure hazards because of:

- Minimal clean up associated with a system discharge
- The removal of the life safety concern
- No environmental impact
- Availability of agent for recharge

When a fire is detected in the protected hazard, the first action is to shut down the process, close off the flow of flammable liquid (if applicable), shut down ventilation and close all doors. An alarm is also sounded to warn personnel of the impending discharge. At this point, solenoid valves are operated at the nitrogen cylinder(s) and the water cylinder to start the flow of water to the nozzles. The nitrogen cylinder(s) provides the force to drive the water through the piping network to the system nozzles. The Micromist system utilizes relatively short duration of water discharges called cycling to aid in the extinguishment of fires. The cycling time for protection of machinery spaces provides enough water for 10 minutes of protection. Refer to the Micromist Design Manual for more details on cycling.

DETECTION AND CONTROLS

Due to the wide range of hazard conditions inside machinery spaces, selecting the type of detection system is critical. Fixed temperature heat detection is the methodology of choice when using a water mist system for protection of these areas. When analyzing a project, consideration shall be given to normal temperatures incurred during system operation as well as ventilation inside the protected area. Additional heat detectors may be needed near the floor where fire hazards are present and ventilation would not allow for sufficient heat build up at the ceiling mounted heat detectors. The Fike Cheetah control panel shall be used to handle the inputs and outputs required for a Micromist system in a machinery space.

The Fike Micromist Water Mist Extinguishing System has been tested by Factory Mutual for protection of machinery space enclosures up to 9,175 ft³(260 m³). A Factory Mutual approved Micromist system protecting a machinery space is shown in the illustration below.

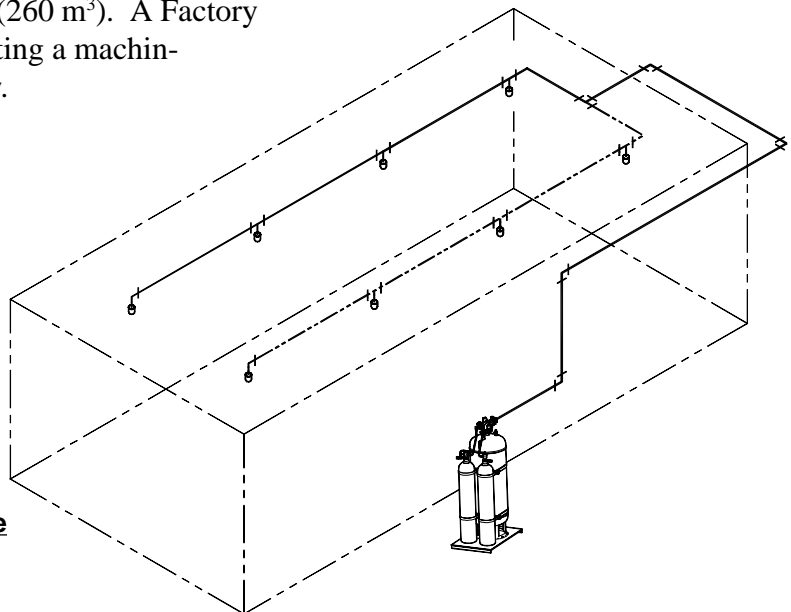

**“Machinery Space” Protected by a Fike
Micromist Extinguishing System**

Fike Corporation

In addition to Fike's Watermist System, Fike has an extensive product offering for facility and process protection for commercial and industrial applications.

Rupture Disc – A pressure relief device, typically applied to a closed chemical process, will open at a predetermined pressure and temperature to prevent the bursting or explosion of the process.

Explosion Venting/Isolation/Suppression - Total Concept Explosion Protection, including explosion testing, explosion venting, explosion isolation, and explosion suppression systems to mitigate the effects of industrial explosions.

Fire Detection Systems – Fike offers a full line of detection products from single hazard to multi zone analog addressable systems. These controls are suited for fire alarm, agent suppression systems, or sprinkler/pre-action fire detection and control systems. The Cheetah analog addressable control panel can be configured to communicate directly with one or more VESDA® LaserPLUS detectors via a High Level Interface (HLI).

Fire Suppression Systems – Fike offers a full range of suppression systems to protect your equipment and/or process. Because Fike offers more than one choice of extinguishing agents you are certain to get the right agent for your hazard. Fike systems incorporate the following agents:

- HFC-227ea
- Carbon Dioxide
- Water Mist



704 South 10th Street • Blue Springs, Missouri 64015-4263 U.S.A.

Phone (816) 229-3405 • Telefax (816) 229-4615 • e-mail fpssales@fike.com • www.fike.com