

Architect and Engineer Specification

USCG - 162.161/2/0
FM - 3002238

Marine Suppression System

DESCRIPTION

The Cylinder Strap provides a means to securely fasten the HFC-227ea container to a structural bulkhead. The Cylinder Saddle is used in conjunction with the Cylinder Strap to stabilize the cylinder when it is mounted. Cylinder Straps and Cylinder Saddles are available in two (2) sizes to accommodate the different container diameters. One or two Cylinder Strap / Cylinder Saddle pairs are required, depending on container size.

Both the Cylinder Straps and Cylinder Saddles are fabricated from cold rolled steel and finished with the same red paint that is utilized on containers. The following table lists the Cylinder Strap / Cylinder Saddle part numbers required for the HFC-227ea Containers.

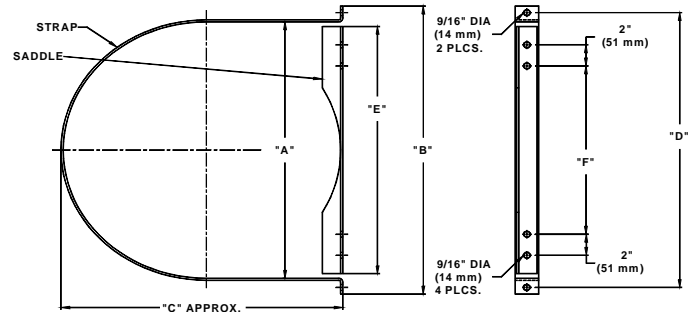

CYLINDER STRAP AND CYLINDER SADDLE

Container Size	Container Part Number	Cylinder Strap Part Number	Cylinder Saddle Part Number
215 lb. (97.5 kg)	N70-087	N70-1309	N70-1001
375 lb. (170 kg)	N70-086	N70-1309	N70-1001
650 lb. (295 kg)	N70-083a	N70-1383	N70-1000
1,000 lb. (454 kg)	N70-090	N70-1383	N70-1000

Cylinder Strap Part Number	Dim "A"	Dim "B"	Dim "C"	Dim "D"
N70-1309	20 3/8" (514 mm)	23 3/8" (594 mm)	20" (508 mm)	22 1/8" (562 mm)
N70-1383	24 3/8" (619 mm)	27 3/8" (69 mm)	24" (610 mm)	26 1/8" (666 mm)

Cylinder Saddle Part Number	Dim "E"	Dim "F"
N70-1001	19 1/2" (495 mm)	12" (304 mm)
N70-1000	23 1/2" (596 mm)	16" (406 mm)

Mounting is accomplished by fastening the Cylinder Strap(s) and Cylinder Saddle(s) to the bulkhead or other structurally sound vertical surface. The container is then held between the two as shown in the following figure.

July, 2002
Revised Issue

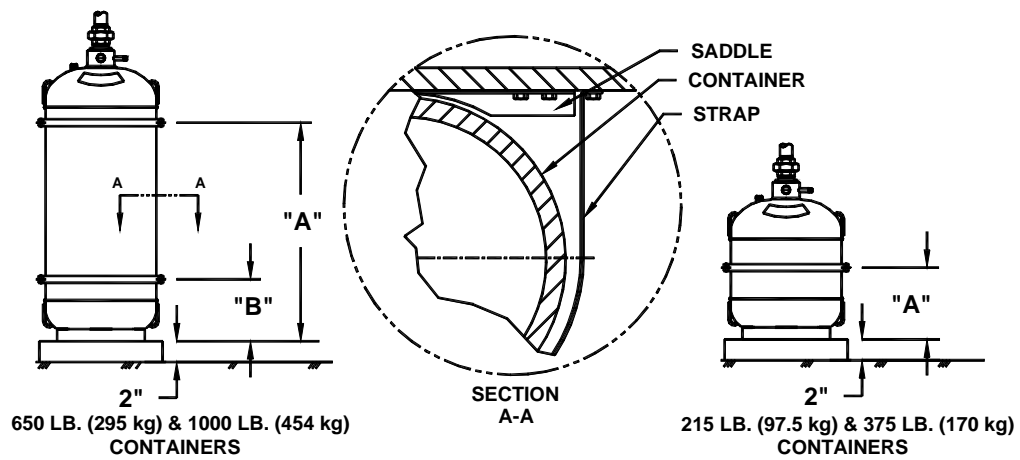

Container Part Number	Container Size	Dim "A"	Dim "B"
N70-087	215 lb. (97.5 kg)	12" (305 mm)	N/A
N70-086	375 lb. (170.0 kg)	26" (660 mm)	N/A
N70-083	650 lb. (295.0 kg)	28" (711 mm)	16" (406 mm)
N70-090	1000 lb. (454.0 kg)	54" (1372 mm)	16" (406 mm)