

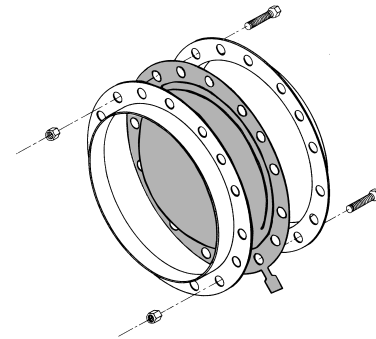

CV Explosion Vent

Explosion Protection Component Sheet #C3741



Typical Explosion Vent
And Mounting Frame

DESCRIPTION

The CV type vent is a composite membrane, high performance explosion vent. CV vents are lightweight and specifically designed for dynamic operation during venting of explosions from industrial equipment. All applicable requirements of NFPA 68, Guide for Venting of Deflagrations, are met with this design. This explosion vent provides excellent service life for static to light pressure cycling conditions.

Venting Efficiency: CV type vents have a venting efficiency of 100%. The mass per area does not exceed 2.5 lbs/ft² as required to use NFPA 68 vent area correlations.

Certified Burst Pressure: The burst pressure, P_{stat} , is determined by destructive testing as required by NFPA 68.

No Maintenance: CV vents have no moving parts and are maintenance-free.

Operating Ratio: Burst pressures are set higher than maximum process operating pressures. The ratio of maximum operating pressure to minimum stamped burst pressure is defined as the operating ratio. CV vents have a 60% to 75% operating ratio, depending on burst pressure.

Vacuum Rating: Explosion vents are often used on equipment that operates under vacuum conditions. CV vents can continuously operate under vacuum levels that do not exceed 60% to 75% of the minimum stamped burst pressure, depending on burst pressure.

Opening: CV vents are designed for controlled full opening in accordance with NFPA 68 requirements.

Fail Safe Design: If the CV vent is damaged, it will provide a relief opening at or below its rated burst pressure.

Location: Care should be taken to locate the explosion vent away from normally occupied areas. At the time of vent opening hazards can originate from the pressure, noise, flame, and/or combustion discharge.

SPECIFICATIONS

Materials of Construction	316 Stainless Steel / Teflon / 316 Stainless Steel
Maximum Operating Pressure	75% of the minimum stamped burst pressure for min. BP ≤ 1.5 psig 60% of the minimum stamped burst pressure for min. BP > 1.5 psig
Maximum Vacuum Rating	75% of the minimum stamped burst pressure for min. BP ≤ 1.5 psig 60% of the minimum stamped burst pressure for min. BP > 1.5 psig
Operating Temperature Range	-40°F to 500°F
Burst Pressure Tolerance	± 0.25 psig for burst pressures less than 1.0 psig ± 0.5 psig for burst pressures between 1.0 psig and 4.0 psig ± 1.0 psig for burst pressures greater than 4.0 psig



SPECIFICATIONS

Vent Size		Relief Area		Minimum Burst Pressure		Maximum Burst Pressure	
in	cm	ft ²	m ²	psig	mbarg	psig	mbarg
9 X 12	23 X 30	0.61	0.057	2.0	138	10.0	690
12 X 12	30 X 30	0.84	0.078	2.0	138	8.0	550
9 X 18	23 X 46	0.94	0.087	2.0	138	10.0	690
12 X 18	30 X 46	1.30	0.12	1.5	103	8.0	550
15 X 15	38 X 38	1.36	0.13	1.5	103	8.0	550
* 12 X 24	30 X 61	1.76	0.16	1.5	103	8.0	550
18 X 18	46 X 46	2.01	0.19	1.0	69	8.0	550
20 X 20	51 X 51	2.51	0.23	1.0	69	8.0	550
18 X 24	46 X 61	2.72	0.25	1.0	69	8.0	550
18 X 30	46 X 76	3.42	0.32	1.0	69	8.0	550
24 X 24	61 X 61	3.67	0.34	1.0	69	8.0	550
* 18 X 35	46 X 89	4.01	0.37	1.0	69	8.0	550
18 X 36	46 X 91	4.13	0.38	1.0	69	8.0	550
24 X 30	61 X 76	4.63	0.43	1.0	69	8.0	550
* 24 X 36	61 X 91	5.59	0.52	0.5	35	8.0	550
30 X 30	76 X 76	5.84	0.54	0.5	35	8.0	550
24 X 44	61 X 112	6.87	0.64	0.5	35	8.0	550
30 X 36	76 X 91	7.05	0.66	0.5	35	8.0	550
36 X 36	91 X 91	8.51	0.79	0.5	35	8.0	550
30 X 44	76 X 112	8.66	0.81	0.5	35	8.0	550
* 36 X 44	91 X 112	10.45	0.97	0.5	35	8.0	550
42 X 42	107 X 107	11.67	1.09	0.5	35	8.0	550
44 X 44	112 X 112	12.84	1.19	0.5	35	8.0	550
44 X 69	142 X 175	20.31	1.89	0.5	35	8.0	550
6 Dia.	15 Dia.	0.14	0.013	3.0	207	15.0	1030
8 Dia.	20 Dia.	0.28	0.026	2.5	172	15.0	1030
10 Dia.	25 Dia.	0.45	0.041	2.0	138	11.0	760
12 Dia.	30 Dia.	0.68	0.063	2.0	138	10.0	690
14 Dia.	36 Dia.	0.95	0.088	1.5	103	10.0	690
16 Dia.	41 Dia.	1.27	0.12	1.25	86	10.0	690
18 Dia.	46 Dia.	1.62	0.15	1.0	69	10.0	690
20 Dia.	51 Dia.	2.02	0.19	1.0	69	10.0	690
24 Dia.	61 Dia.	2.95	0.27	1.0	69	10.0	690
30 Dia.	76 Dia.	4.67	0.43	0.5	35	10.0	690
32 Dia.	81 Dia.	5.33	0.50	0.5	35	10.0	690
36 Dia.	91 Dia.	6.78	0.63	0.5	35	10.0	690
40 Dia.	102 Dia.	8.40	0.78	0.5	35	10.0	690
42 Dia.	107 Dia.	9.28	0.86	0.5	35	10.0	690
44 Dia.	112 Dia.	10.20	0.95	0.5	35	10.0	690

* These sizes are stocked at the factory for 1.5 psig nominal burst pressure only.