

COAL PULVERIZER

FUNCTIONALITY

Raw coal is fed into the coal inlet, dried and ground to a fine dust on the grinding table. Hot air (inert gas) is used to pneumatically carry the coal dust upward through the classifier and into the transport pipe.

EXPLOSION HISTORY

Loss history for the past ten years due to dust explosions from FM Global Data Sheet 7-76:

- Six in ball/hammer mills for a loss of \$2,012,000
- Ten in Pulverizer/Fragmentizers for a loss of \$1,643,000

SOURCES OF IGNITION

- Tramp metal, i.e. railroad spikes, and pyrites are a typical source for ignition
- A loss history evaluation for a recent twelve year period indicates that a loss of inerting or not following inerting procedures was a factor in all explosion incidents.¹
- Many explosion incidents resulted when proper isolation, clearing, or shutdown procedures were not followed.¹
- Half of all explosions occurred during a hot restart.¹
- Hot furnace gases backing up into the pulverizer system was responsible for several explosions.¹

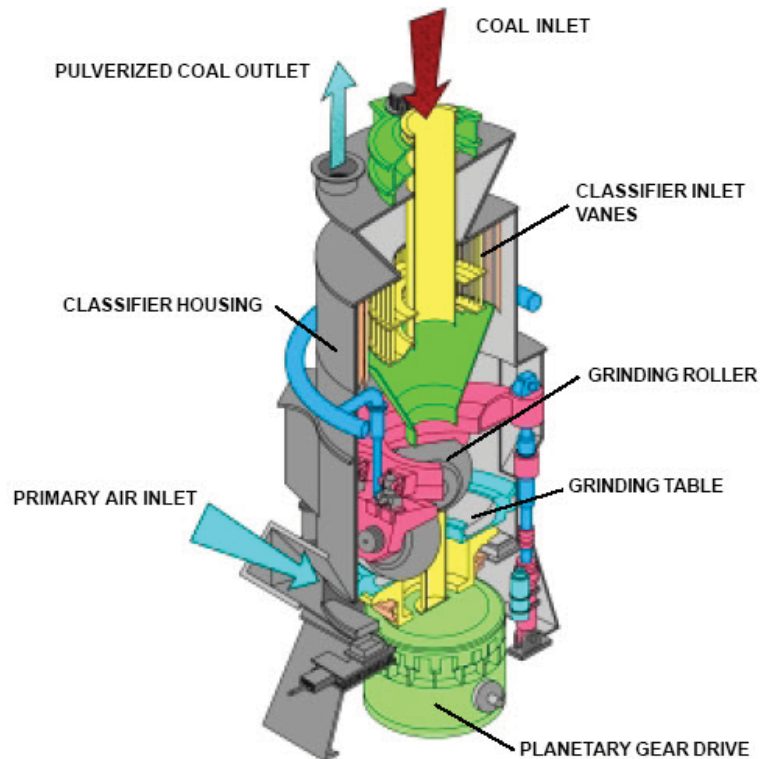

Figure 1: Typical Cross-Sectional View of a Pulverizer

Form No. EAP 1009

SOLUTION

Explosion Venting of the pulverizer is not allowed per NFPA 8503 of FM 6-24/13-21, so this equipment is best protected by either containment (tested to 200 psi), or an explosion suppression system. Chemical isolation should be used on the inlet and outlet to prevent flame propagation to other equipment.

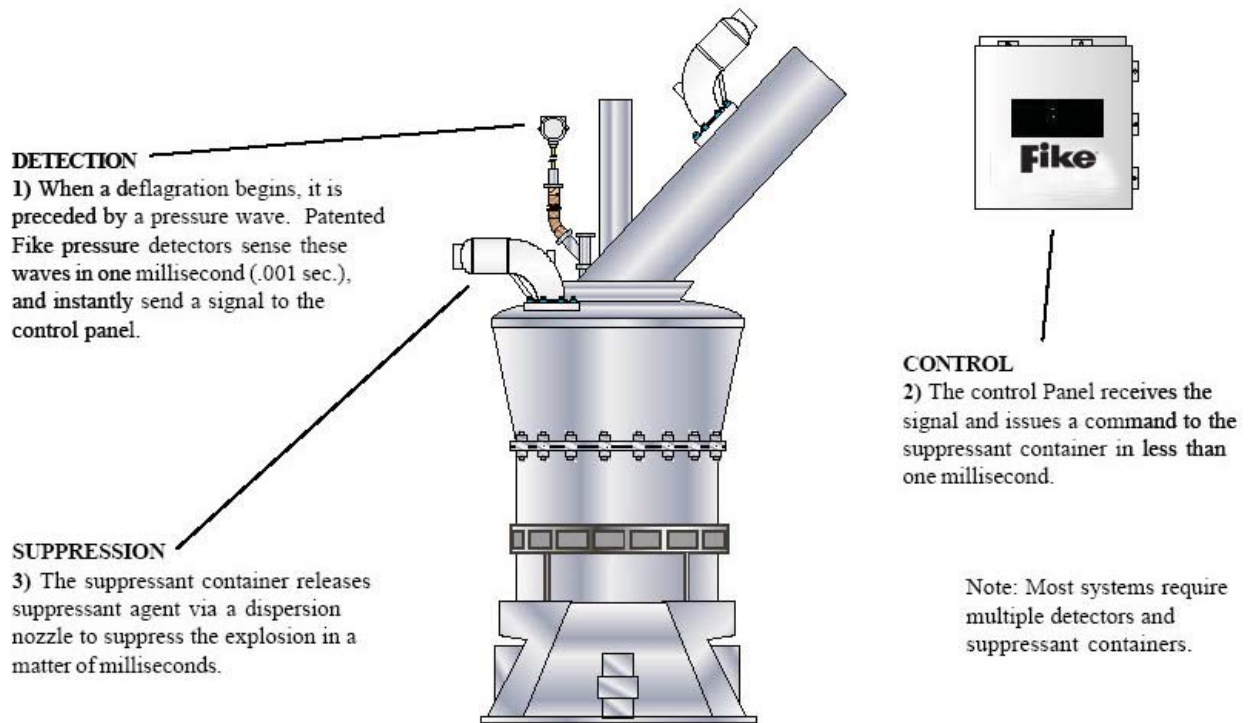

Figure 2: Pulverizer Protected by Explosion Suppression and Chemical Isolation

