

## CO<sub>2</sub> VENT NOZZLES

### DESCRIPTION

The Vent Nozzle is used for total flooding systems protecting ductwork, electrical compartments, collecting bins, or any other application that requires direct mounting of the nozzle.

Nozzle strainers are required on any nozzle with an orifice code requirement of 3 or smaller. Nozzle strainers do not come with the vent nozzle, and must be ordered separately. (Refer to nozzle strainer detail).

The Vent Nozzle is made of brass or stainless steel and is available with orifice code sizes ranging from (1) through (13.5).

The Vent Nozzle flange mounting kit is used to mount a vent nozzle to the mounting surface of an enclosure, hood, ductwork, etc. A teflon sealing disc is included for the purpose of preventing the discharge orifice from becoming obstructed when the nozzle is used in a dirty environment. A new sealing disc will be required after each system discharge.

The flange kit is attached to the mounting surface with (3) 3/16" (5 mm) sheet metal or self-tapping screws located on a 2-1/2" (63.5 mm) bolt circle. Prior to attaching the flange kit, a 1-1/2" to 2" (40 to 50 mm) diameter clearance hole must be cut in the mounting surface.

The assembly of the flange kit is completed by inserting the sealing disc and "O" ring into the body and then tightening down the vent nozzle to approximately 20 ft./lbs.



### SPECIFICATIONS

Part Number:	C80-020 B or S Vent Nozzle C80-1013 Flange and Seal Kit C02-1181 Strainer C80-1011 Seal Disc
Material:	Brass Nozzle Mounting Stainless Steel Mounting Flange Teflon Seal Disc

### APPROVALS

- ULC - CEx 1312
- USCG - 162.038/12/0

Form No. E.1.06.01-1

## VENT NOZZLE WITH FLANGE MOUNTING KIT DETAILS

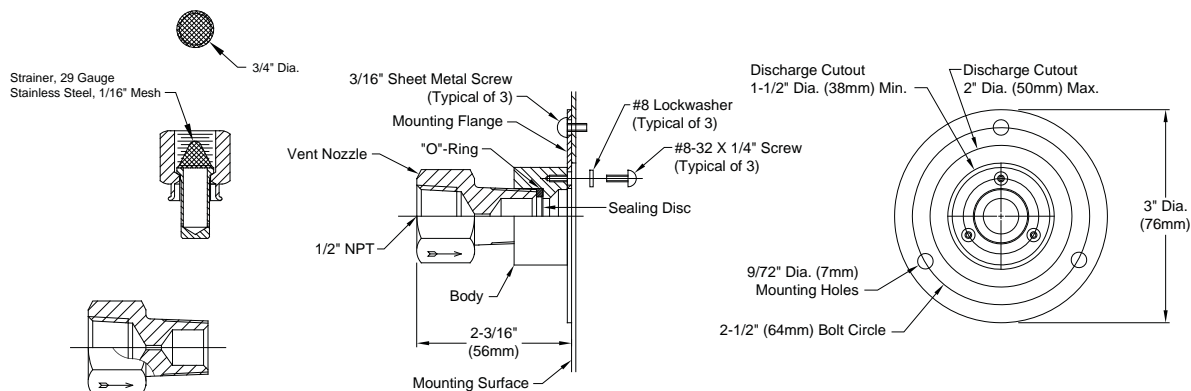

## VENT NOZZLE WITH NOZZLE STRAINER

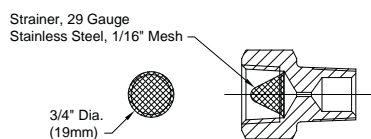

## VENT NOZZLE WITH FLANGE MOUNTING KIT

