

## PNEUMATIC TIME DELAY

### DESCRIPTION

The pneumatic time delay delays the discharge of CO<sub>2</sub> for a predetermined amount of time. This extra time allows personnel to get out of the discharge area. It also allows additional time for ventilation and equipment shutdown.

The time delay is installed between the master CO<sub>2</sub> cylinders and the discharge nozzles. The time delay has an inlet port and an outlet port, both with a 1" NPT connection. The actual time delay period is pre-set at the factory. Fike offers both 30 and 60 second time delays.

The time delay will operate at temperatures from 0 to 130°F. Note: delay times will vary slightly with the ambient temperature.

The time delay is equipped with a manual override lever. This lever allows the time delay to be bypassed and allows the CO<sub>2</sub> to discharge immediately.

### INSTALLATION

The pneumatic time delay is installed onto the discharge piping of the manifold. The valve body has a 1" NPT (25mm) threaded inlet and outlet for the piping connection. It is recommended that a union be placed on either side of the time delay for ease of removal.

In a CO<sub>2</sub> system the pneumatic time delay must be placed after the Master cylinder(s) and before the slave cylinder(s) connection(s) in the manifold. Refer to the typical arrangement drawings for installation configuration.

### SPECIFICATIONS

Part Number:	C70-235 (30 second delay) C70-237 (60 second delay)
Dimensions:	5 3/4" x 4 1/2" x 26 1/8" (146 x 117 x 664mm)
Materials:	Time Delay Valve - Brass Override lever - Stainless Steel Cylinder and Bracket - Painted (Red gloss enamel)

### APPROVALS

- UL - Ex 4447
- ULC - CEx 1312
- FM
- USCG - 162.038/12/0 (CO<sub>2</sub>)

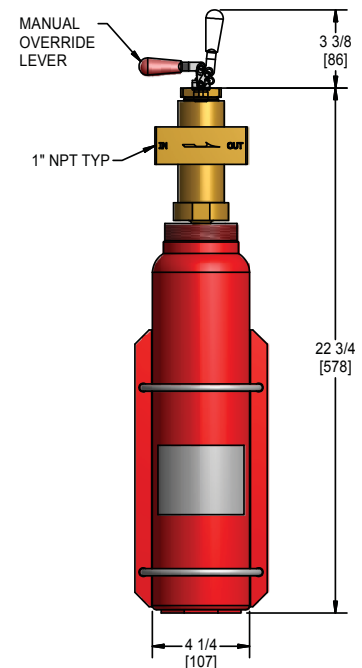

Form No. E.1.29.01

*(This page is left blank intentionally)*

