

## PULVERIZED COAL IN POWER PLANTS

- 1999, Coal Supplied 56% of the nations electricity.
- ~90% of coal mined in US goes to power plants.
- To meet forecasted electricity demand over the next 20 years, it is estimated that a staggering 2,000 MW of capacity, equivalent to two major power stations, will have to be built every week throughout the world - some 25% or more based on coal.
- Coal injection provides a unique opportunity to reduce coke usage and increase furnance productivity of blast furnaces. Additional, coal injection offsets or eliminates the costs associated with coke oven rebuiltds and repairs.
- The DOE estimates that the market for clean coal technologies will climb to \$870 billion by the year 2010.

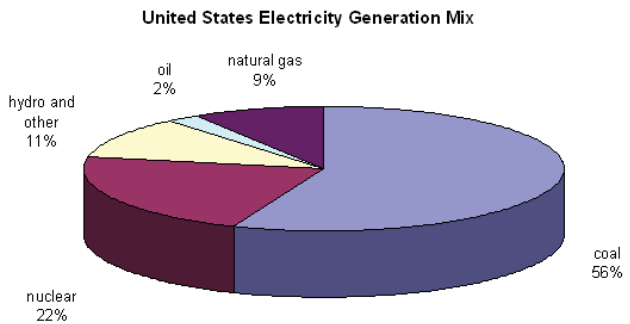

## PULVERIZED COAL EXPLOSIONS IN POWER PLANTS

- Coal is fed into a pulverizer where it is crushed and dried using hot air at approximately 300°F. The coal is then pneumatically transported to the dust collector where the pulverized coal is collected and either fed directly to the boiler or to a storage bin.
- During normal operation the coal stream is inerted with nitrogen or similar gas. The problem typically occurs during startup, shutdown or failure of the inerting system.
- It is not uncommon for tramp metal, railroad spikes, or similar to be fed into the grinder and thus creating sparks. These sparks can travel from the pulverizer through the transport pipe and into the dust collector. The dust collector is a big source of static electricity because the atmosphere is typically at ~200°F with the dry coal dust suspended.
- The other common ignition source is pyrites that are collected below the pulverizing bed. If there is a failure of the inert gas source then air is introduced and the pyrites can ignite the coal dust.
- Coal is milled to a fine powder in a pulverizer - this increases the surface area of the coal and hence the rate of combustion. The powdered coal is blown into the combustion chamber of a boiler where it is burnt at around 1400°C.
- “Explosions on Tuesday shook a coal-fired generating plant that supplies power to Chicago, ... Jim Walsko, chief fire inspector, said he believes a spark ignited coal dust but, ‘It could have been static electricity, it could have been anything.’... The plant is operated by State Line Energy, a subsidiary of Southern Energy, which bought the Hammond plant from Chicago-based ComEd in December. It is undergoing a \$65 million upgrade, said Mike Tyndall, a spokesman for Atlanta-based Southern Co., parent of Southern Energy. ... said it was the third fire this year at a coal-burning facility owned by Commonwealth Edison or that supplies power to the utility.” - Wednesday, July 29, 1998 “The Detroit News” <http://detnews.com/1998/nation/9807/29/07290113.htm>
- Explosion at the Ford Rouge Plant in Dearborn, MI in February 1987, February 1999, January 2001. <http://www.freep.com/news/locway/qdust3.htm>



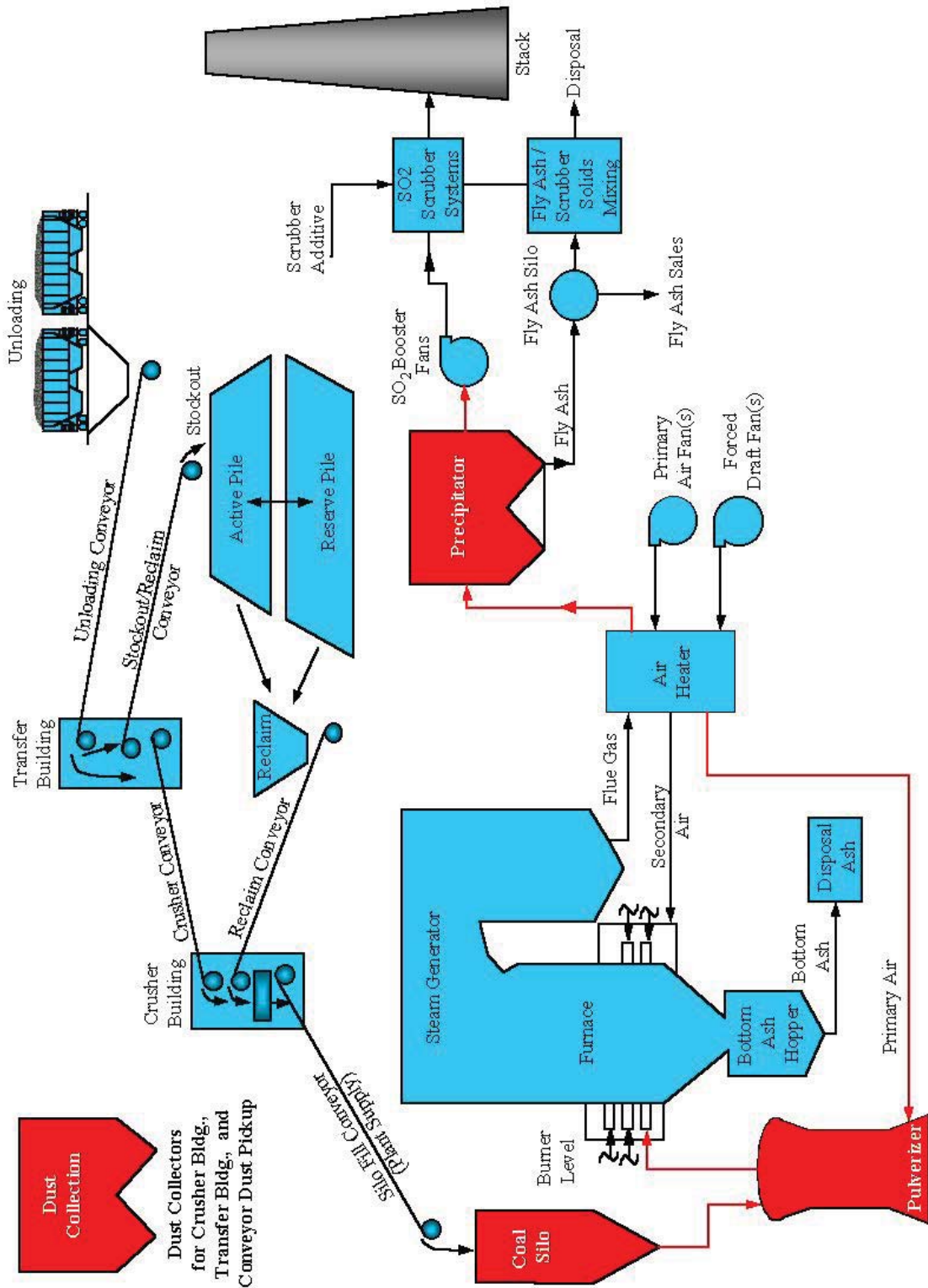

Copyright © Fike Corporation All Rights Reserved.  
 Form No. EAP 1015 October, 2001 Specifications are subject to change without notice.

# COAL PULVERIZER

## FUNCTIONALITY

Raw coal is fed into the coal inlet, dried and ground to a fine dust on the grinding table. Hot air (inert gas) is used to pneumatically carry the coal dust upward through the classifier and into the transport pipe.

## EXPLOSION HISTORY

Loss history for the past ten years due to dust explosions from FM Global Data Sheet 7-76:

- Six in ball/hammer mills for a loss of \$2,012,000
- Ten in Pulverizer/Fragmentizers for a loss of \$1,643,000

## SOURCES OF IGNITION

- Tramp metal, i.e. railroad spikes, and pyrites are a typical source for ignition
- A loss history evaluation for a recent twelve year period indicates that a loss of inerting or not following inerting procedures was a factor in all explosion incidents.<sup>1</sup>
- Many explosion incidents resulted when proper isolation, clearing, or shutdown procedures were not followed.<sup>1</sup>
- Half of all explosions occurred during a hot restart.<sup>1</sup>
- Hot furnace gases backing up into the pulverizer system was responsible for several explosions.<sup>1</sup>

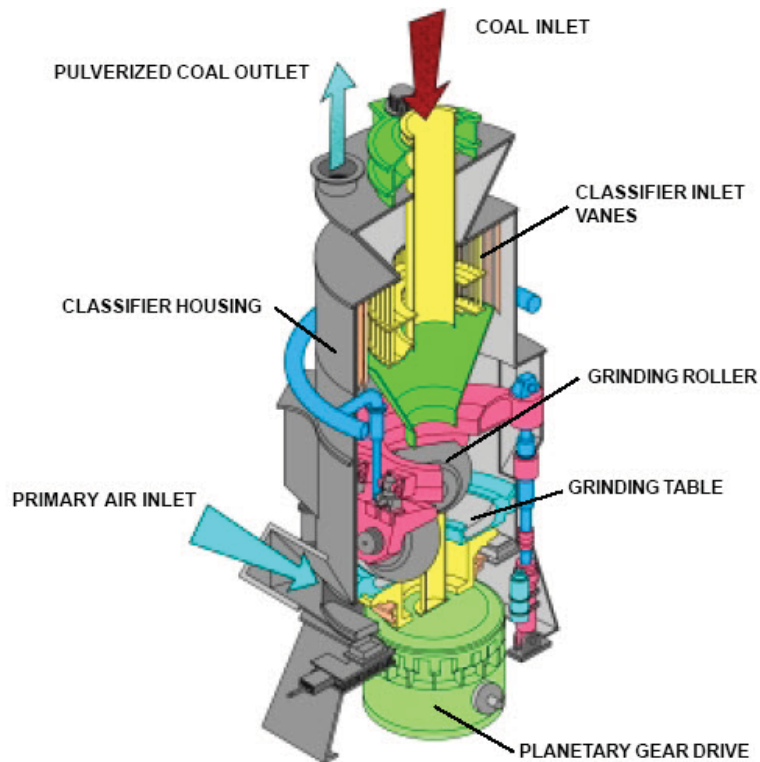

**Figure 1: Typical Cross-Sectional View of a Pulverizer**

## SOLUTION

Explosion Venting of the pulverizer is not allowed per NFPA 8503 of FM 6-24/13-21, so this equipment is best protected by either containment (tested to 200 psi), or an explosion suppression system. Chemical isolation should be used on the inlet and outlet to prevent flame propagation to other equipment.

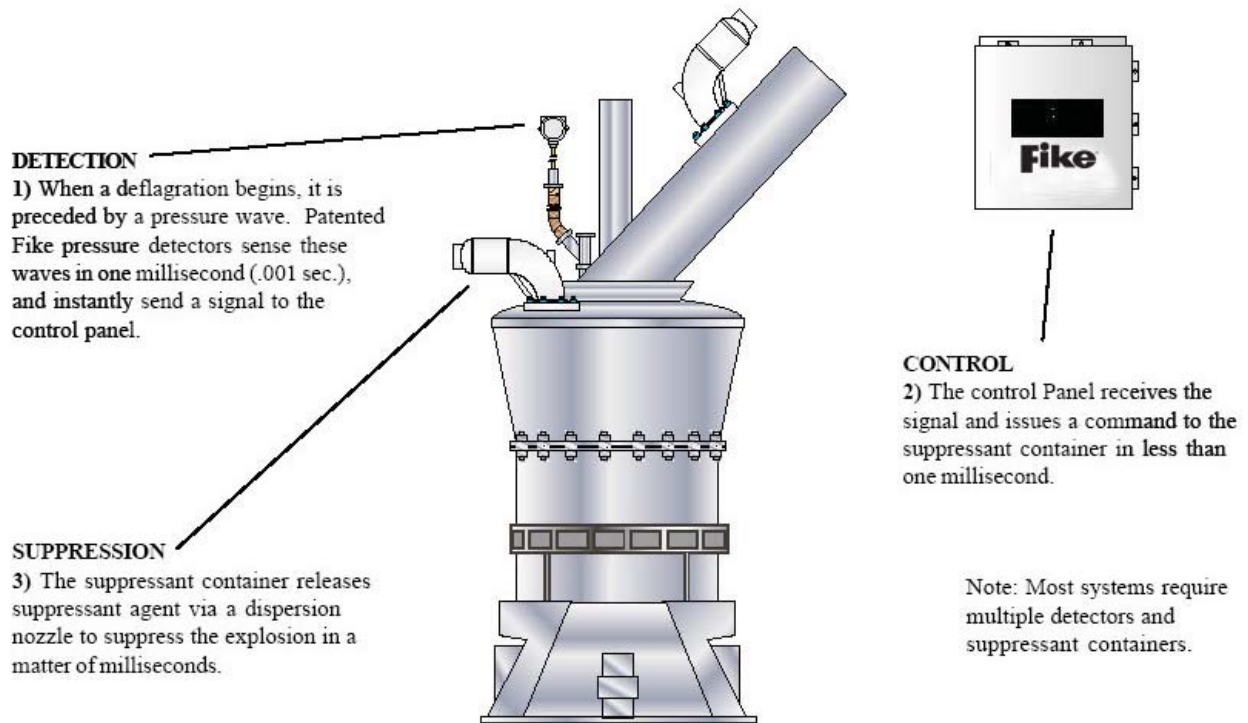

Figure 2: Pulverizer Protected by Explosion Suppression and Chemical Isolation



# DUST COLLECTOR

## FUNCTIONALITY

A dust collector (bag house) is typically a low strength enclosure that separates dust from a gas stream by passing the gas through a media filter. The dust is collected on either the inside or the outside of the filter. A pulse of air or mechanical vibration removes the layer of dust from the filter. This type of filter is typically efficient when particle sizes are in the 0.01 to 20 micron range.

## EXPLOSION HISTORY

- Loss history shows that dust collectors are by far the leading piece of equipment to experience explosions.<sup>1</sup>
- Loss history for the past ten years due to dust explosions from FM Global Data Sheet 7-76:
  - Fifty-eight in dust collectors for a loss off \$15,094,000.

## SOURCES OF IGNITION

- Because dust collectors are designed to handle material produced elsewhere, the ignition source does not have to come from within the dust collector. It may come from other equipment downstream of the dust collector.
- Sparks, flame, or smoldering embers, from dust production areas, are potential ignition sources that can ignite an explosion in the dust collector.

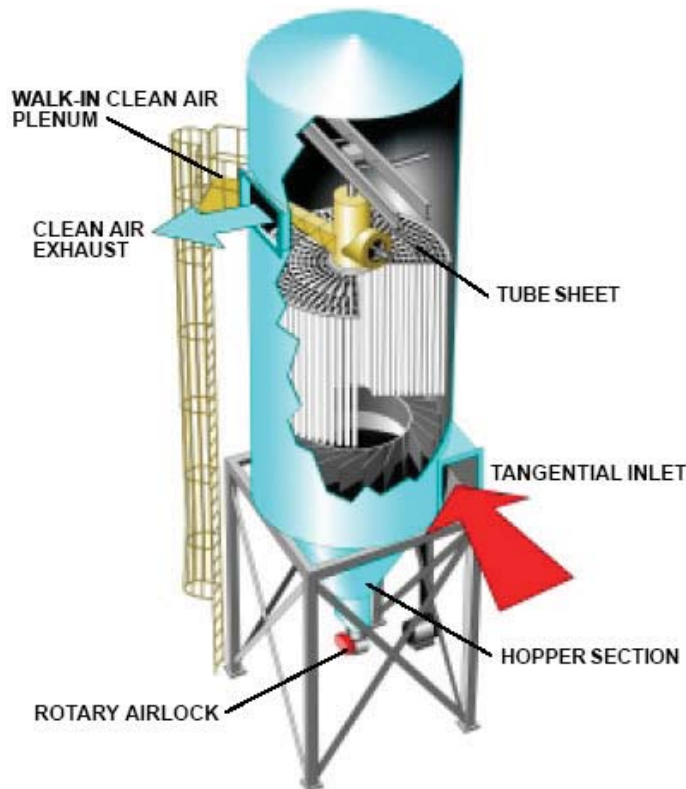

**Figure 1: Sectional View of a Dust Collector**

## SOLUTION

Dust collectors are best protected by either explosion venting and/or explosion suppression systems. In both cases chemical isolation should be used on the inlet to prevent flame propagation to other equipment.

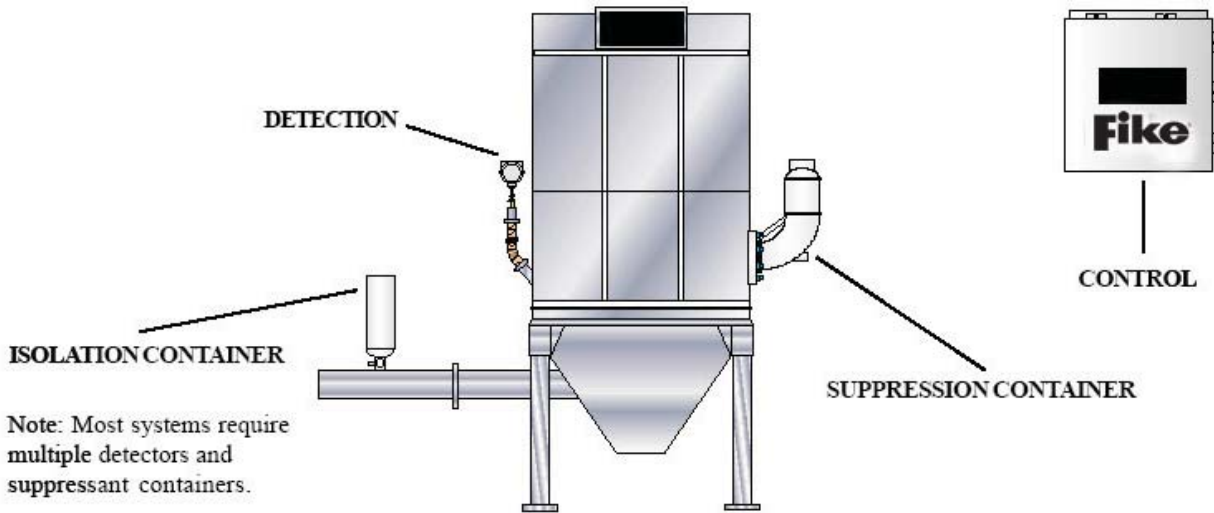

**Figure 2: Dust Collector Protected by Explosion Suppression and Chemical Isolation**

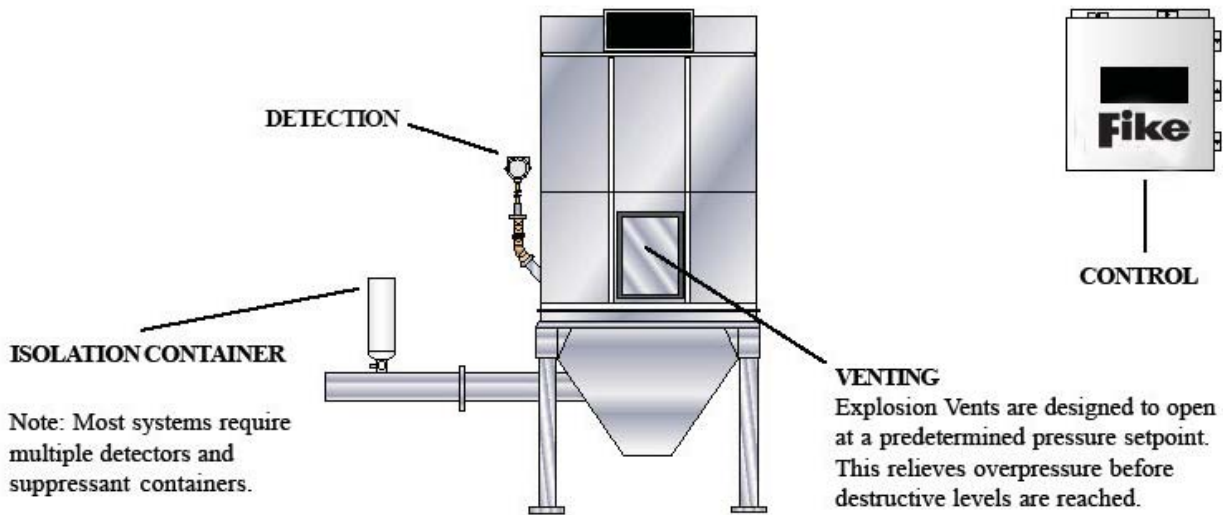

**Figure 3: Dust Collector Protected by Explosion Venting and Chemical Isolation**

# Fike®

Copyright © Fike Corporation All Rights Reserved.  
Form No. EAP 1010 October, 2001 Specifications are subject to change without notice.

# CYCLONE

## FUNCTIONALITY

Dust laden gas enters the chamber from a tangential direction at the outer wall of the device, forming a vortex as it swirls within the chamber. The larger particulates, because of their greater inertial, move outward and are forced against the chamber wall. Slowed by friction with the wall surface, they then slide down the wall into a conical dust hopper at the bottom of the cyclone. The cleaned air swirls upward in a narrower spiral through an inner cylinder and emerges from an outlet at the top. Accumulated particulate dust is deposited into a hopper, dust bin or screw conveyor at the base of the collector.

Cyclones are best at removing relatively coarse particulates. They can routinely achieve efficiencies of 90% for particles larger than about 20  $\mu\text{m}$  (0.008 inch). By themselves, however, cyclones are not sufficient to meet stringent air quality standards. They are typically used as pre-cleaners and are followed by more efficient air-cleaning equipment such as electrostatic precipitators and bag houses.

## EXPLOSION HISTORY

- Loss history for the past ten years due to dust explosions from FM Global Data Sheet 7-76:
  - Twenty-seven losses involved coal dust for a loss of \$12,056,000

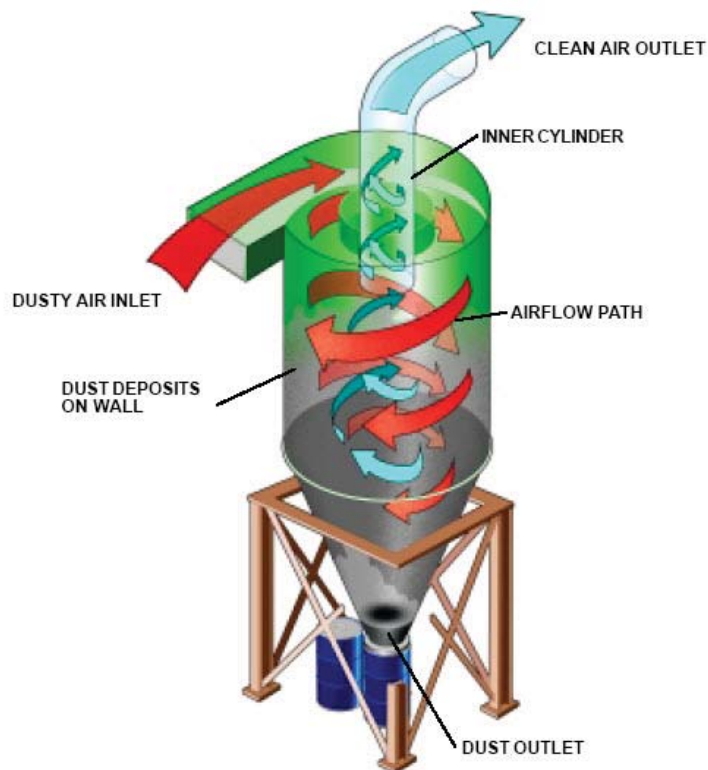

Figure 1: Cyclone Operation

## SOURCES OF IGNITION

Because cyclone collectors are designed to handle material produced elsewhere, the ignition source does not have to come from within the cyclone collector. It may come from other equipment upstream or downstream of the cyclone.

Sparks, flame, or smoldering embers, from dust production areas, are potential ignition sources that can ignite an explosion in the cyclone collector.

## SOLUTION

Cyclone collectors are best protected by explosion suppression systems. Chemical isolation should be used on the inlet and outlet to prevent flame propagation to other equipment.

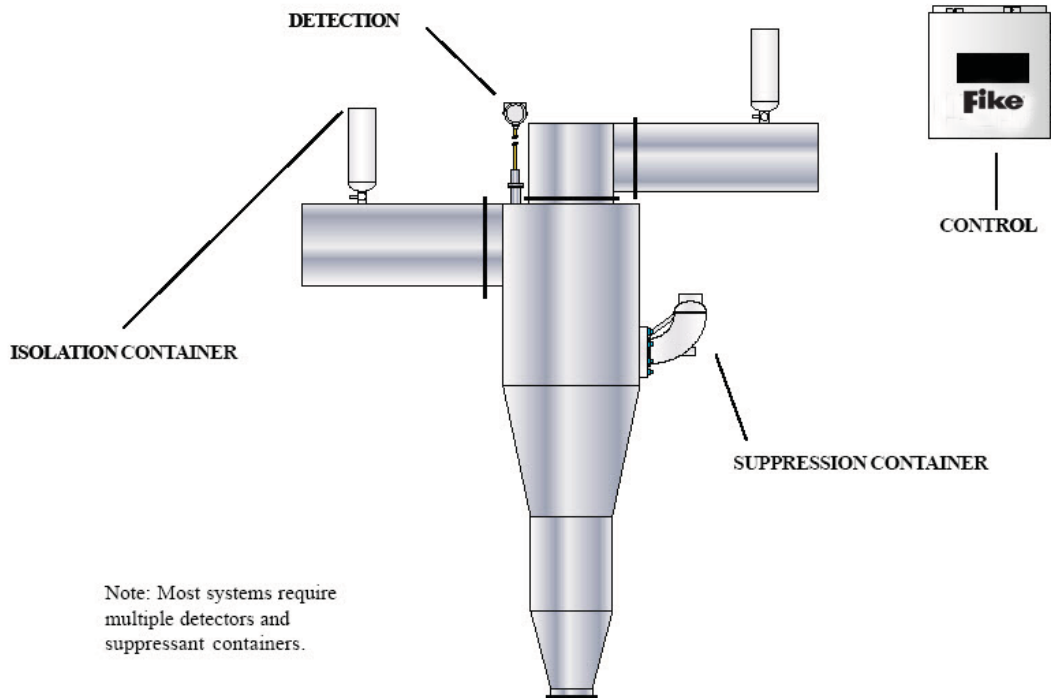

Figure 2: Cyclone Protected by Explosion Suppression and Chemical Isolation



# ELECTROSTATIC PRECIPITATOR

## FUNCTIONALITY

In an electrostatic precipitator, particles suspended in the air stream are given an electric charge as they enter the unit and are then removed by the influence of an electric field. A high DC voltage (as much as 100,000 volts) is applied to the discharge electrodes to charge the particles, which then are attracted to oppositely charged collection electrodes, on which they become trapped.

Particles that stick to the collection plates are removed periodically when the plates are shaken or “rapped.” Rapping is a mechanical technique for separating the trapped particles from the plates, which typically become covered with a 6-mm (0.2 inch) layer of dust. An electrostatic precipitator can remove particulates as small as 1  $\mu\text{m}$  (0.00004 inch) with an efficiency exceeding 99%. The effectiveness of electrostatic precipitators in removing fly ash from the combustion gases of fossil-fuel furnaces accounts for their high frequency of use at power stations.

## EXPLOSION HISTORY

- Loss history for the past ten years due to dust explosions from FM Global Data Sheet 7-76:
  - Four in electrostatic precipitators for a loss of \$2,988,000

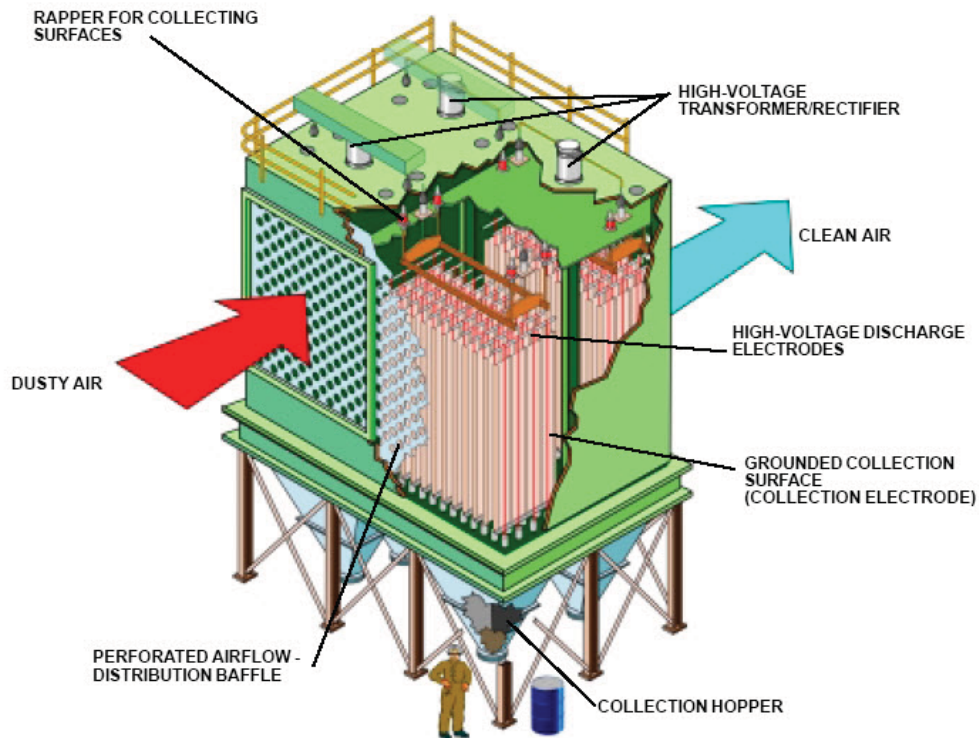

Figure 1: Sectional View of an Electrostatic Precipitator

## SOURCES OF IGNITION

Due to continuous spark generation and mechanical rapping, ignition sources are readily present in the electrostatic precipitator. Because electrostatic precipitators are designed to handle material produced elsewhere, the ignition source does not have to come from within the electrostatic precipitator.

## SOLUTION

One way of protecting electrostatic precipitators is through the use of explosion venting. Chemical isolation should be used on the inlet to prevent flame propagation to other equipment.

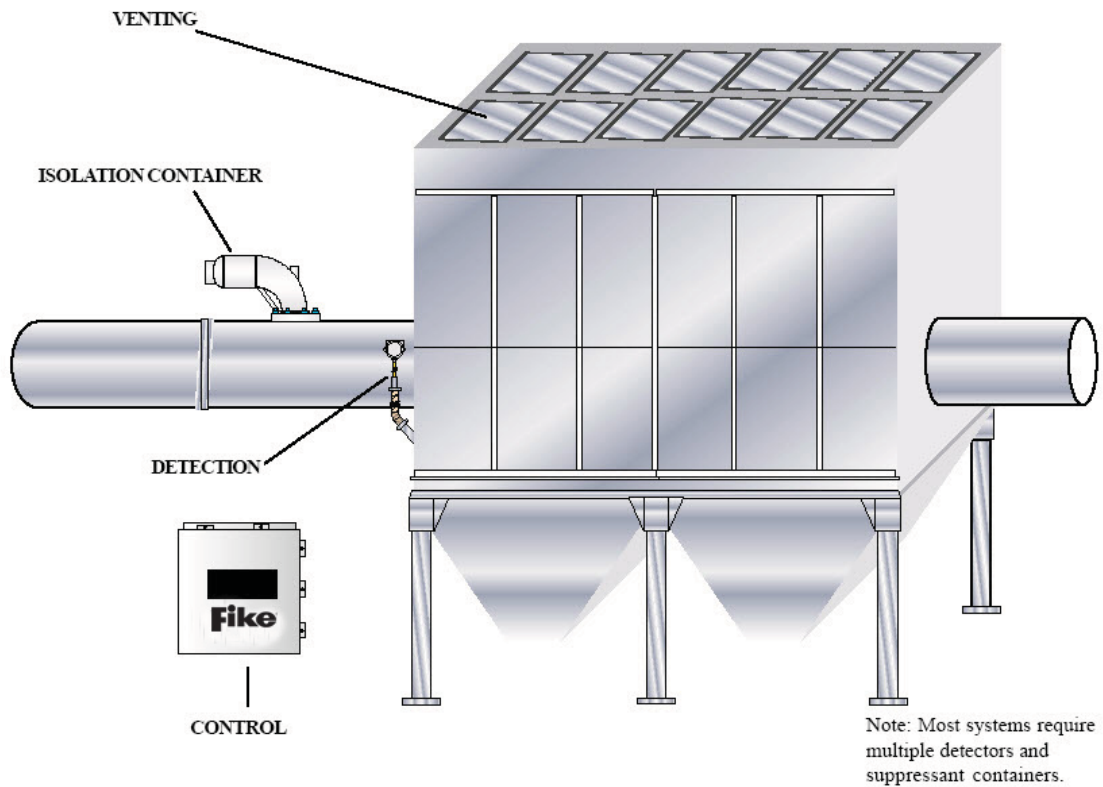

Figure 2: Electrostatic Precipitator Protected by Explosion Venting and Chemical Isolation



# STORAGE BIN

## FUNCTIONALITY

A storage bin can contain either raw coal for feeding into the pulverizer, or pulverized coal for feeding into the burner. Typically coal is fed into the top of the storage bin. The heavy particles of coal settle in the hopper, while dust becomes suspended in the upper section. The dust can be the fines created during pulverizing, or the fines that are a by-product of abrasion as the coal being moved from one piece of equipment to another.

## EXPLOSION HISTORY

- Loss history for the past ten years due

## FUNCTIONALITY

Transport pipes and ducts are enclosures that move coal dust from one piece of equipment to another, or that brings heated gases into the equipment for process operation. These enclosures can range from lightweight sheet metal to heavy wall pipe. They can be round with diameters up to approximately 5 feet, or rectangular with cross sections up to approximately 2'x3'.

## EXPLOSION HISTORY

- Damage to transport pipes and ducts are usually the result of an explosion in a connected piece of equipment. For example, an explosion that occurred in the pulverizer usually damages the pulverizer heated gas inlet, because the inlet is of lightweight construction.
- Loss history for the past ten years due to dust explosions from FM Global Data Sheet 7-76:
  - Eight in coal processing for a loss of \$4,654,000

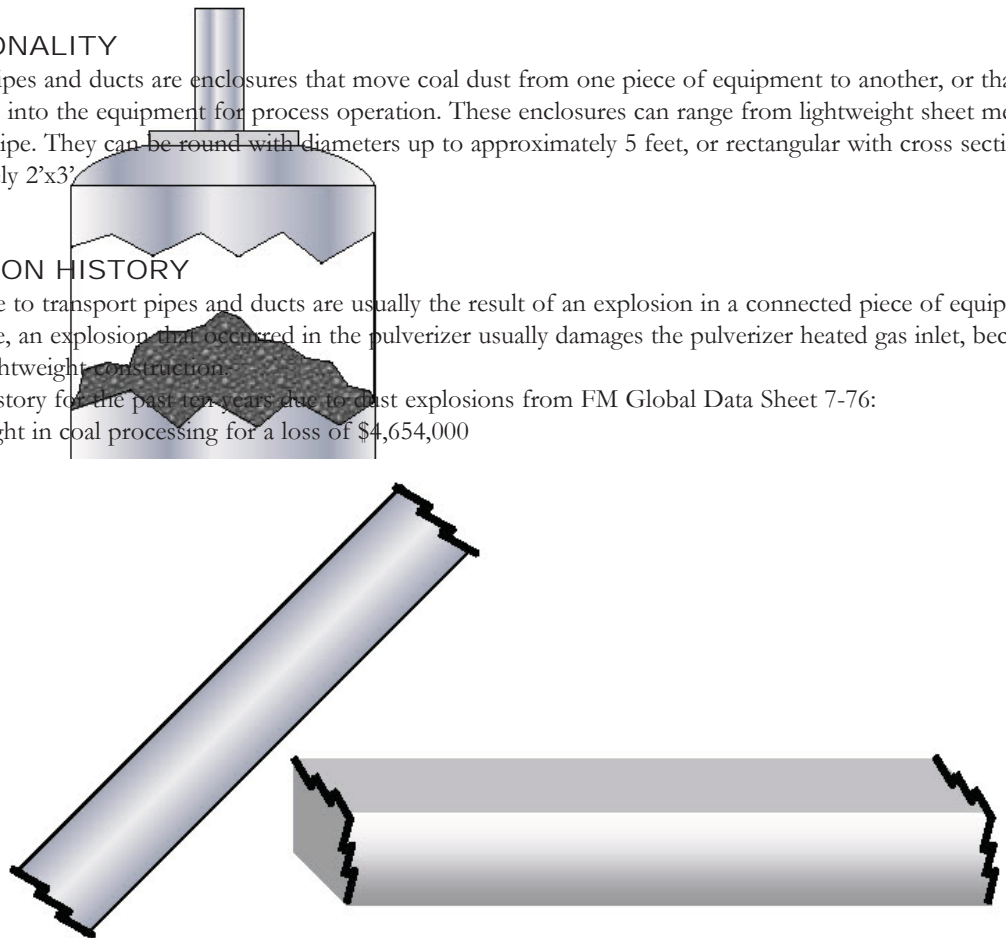

to dust explosions from FM Global Data Sheet 7-76:

- Seven in storage silos/bins for a loss of \$4,002,000

Figure 1: Ducts and Pipes

## SOURCES OF IGNITION

Due to continuous spark generation and mechanical rapping, ignition sources are readily present in the electrostatic precipitator. Because electrostatic precipitators are designed to handle material produced elsewhere, the ignition source does not have to come from within the electrostatic precipitator.

## SOLUTION

One way of protecting electrostatic precipitators is through the use of explosion venting. Chemical isolation should be used on the inlet to prevent flame propagation to other equipment.

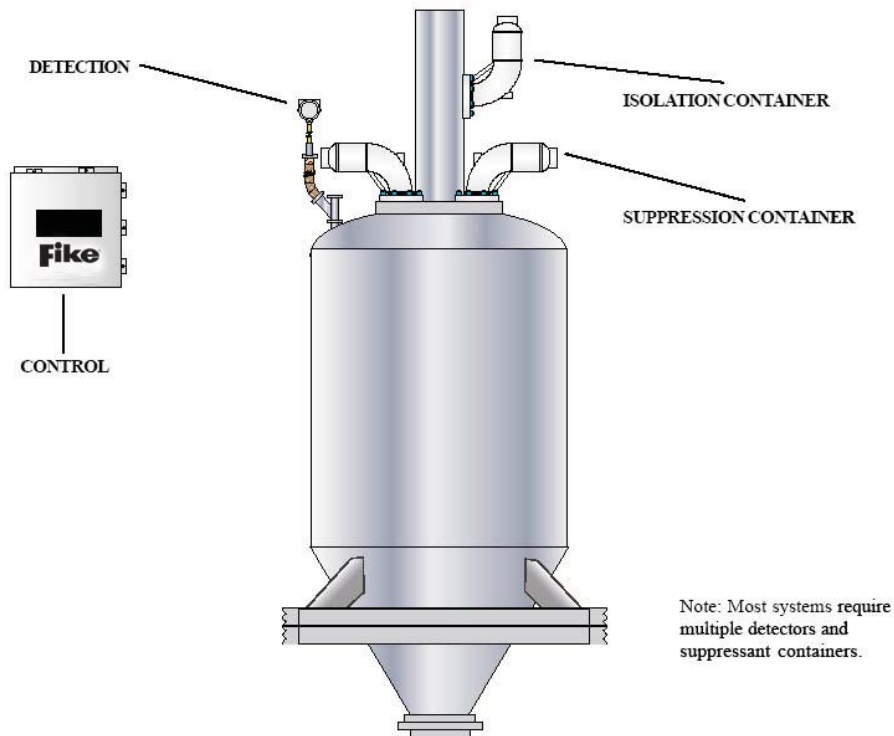

Figure 2: Storage Bin Protected by Explosion Suppression and Chemical Isolation



## DUCTS AND PIPES

### FUNCTIONALITY

Transport pipes and ducts are enclosures that move coal dust from one piece of equipment to another, or that brings heated gases into the equipment for process operation. These enclosures can range from lightweight sheet metal to heavy wall pipe. They can be round with diameters up to approximately 5 feet, or rectangular with cross sections up to approximately 2'x3'

### EXPLOSION HISTORY

- Damage to transport pipes and ducts are usually the result of an explosion in a connected piece of equipment. For example, an explosion that occurred in the pulverizer usually damages the pulverizer heated gas inlet, because the inlet is of lightweight construction.
- Loss history for the past ten years due to dust explosions from FM Global Data Sheet 7-76:
  - Eight in coal processing for a loss of \$4,654,000

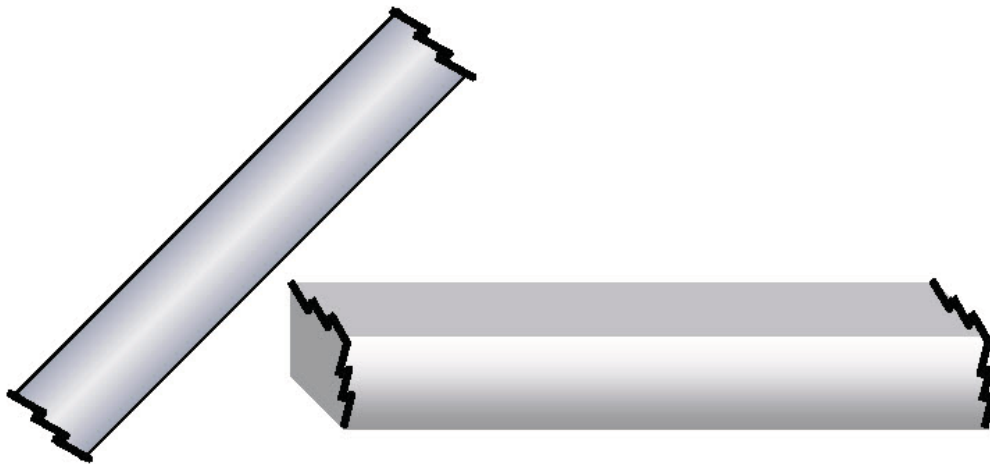

Figure 1: Ducts and Pipes

## SOURCES OF IGNITION

Sparks, flame, or smoldering embers are potential ignition sources that can ignite an explosion in transport pipes and ducts.

## SOLUTION

Transport pipes and ducts are best protected by either an explosion chemical isolation system, or by explosion venting.

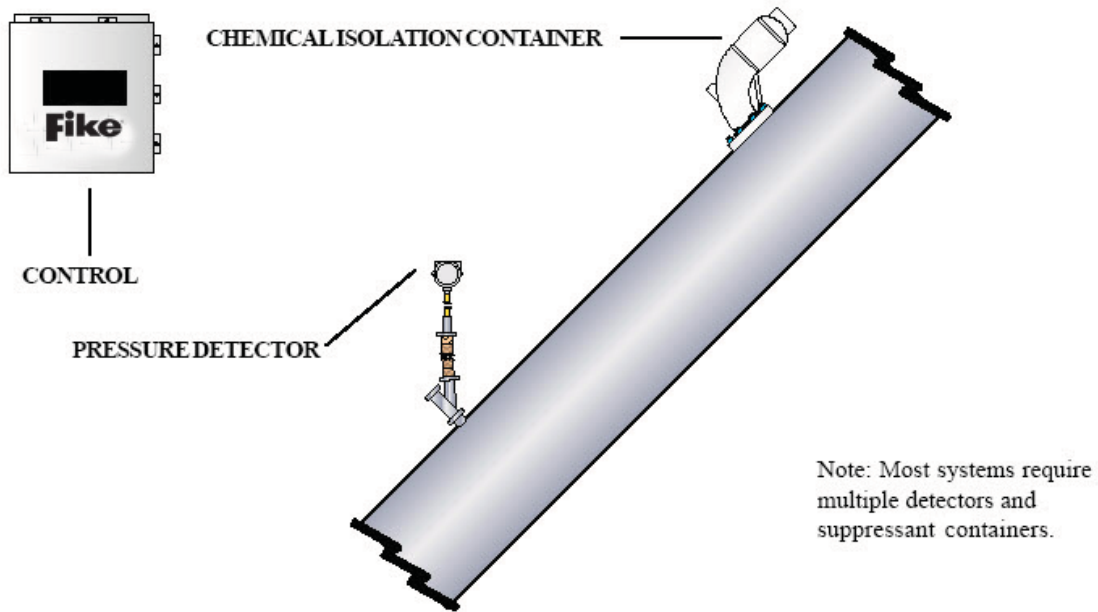

Figure 2: Transport Pipe Protected by Chemical Isolation

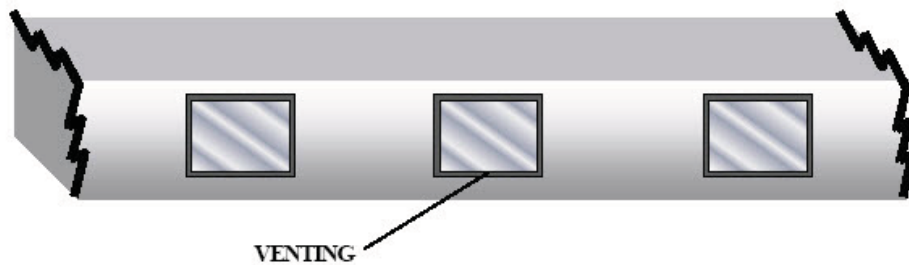

Figure 3: Heated Air Duct Protected by Explosion Venting

