

## BALL VALVE LOCKOUT ASSEMBLIES

### DESCRIPTION

Fike Ball Valve Lockout Assemblies provide a means to physically prevent an accidental discharge of an explosion suppression or isolation container into the process vessel. Each Ball Valve is equipped with electrical contact switches that prevent the unintentional arming of the explosion protection system controller (EPC).

Ball Valve Lockout Assemblies come in a wide array of sizes to safely protect all Fike High Rate Discharge (HRD) and Standard Rate Discharge (SRD) explosion protection containers.

All Ball Valve Lockout Assemblies are available in either carbon (painted white) or stainless steel and include a vent hole with a nylon blowout plug to safely relieve the pressure in the case of an unintentional discharge of the explosion protection container while the ball valve is in the closed position.

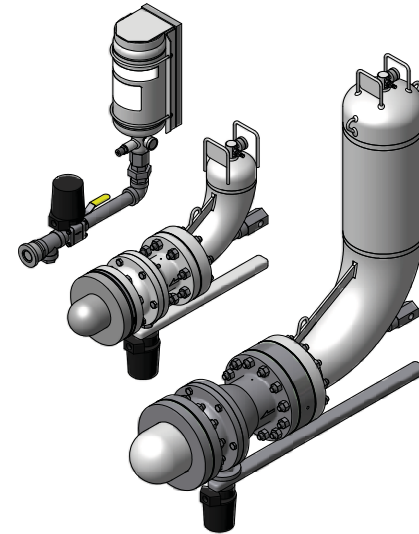

### FEATURES AND BENEFITS

- Compatible with 2.5, 5, 10, 20, 30 and 50 Liter HRD containers; 9L SRD container
- Over-pressure vent hole and nylon plug
- Visual position indicators (open / closed)
- Explosion and weather proof position indicating switches
- Can be added to existing HRD & SRD installations
- Satisfies OSHA Lockout/Tagout requirements
  - 29CFR 1910.147, The Control of Hazardous Energy
- Satisfies NFPA 69-2007, 10.3 Personnel Safety requirements
- Satisfies EN 14373, 8 Instructions for installation, commissioning and maintenance
- Fail safe interlock with controller and process
- Manual operation

### POSITION INDICATOR SWITCH SPECIFICATIONS

Output Switch:	Two micro switches, SPDT, 15A @ 125/250 VAC
Hazardous Locations Approvals	Weatherproof and flameproof. NEMA 1, 2, 3, 3R, 3S, 4, 4X, 6, 7, 9, 12, 13. UL rated: Class I, Division 1 & 2, Groups B, C, D; Class II, Division 1 & 2, Groups E, F, and G. CSA rated: Class I, Division 1 & 2, Groups A, B, C, D; Class II, Division 1 & 2, Groups E, F and G SAA rated: -S suffix, Certified Ex d IIC T6 IP68 (15 meters)

Form No. X.1.44.01

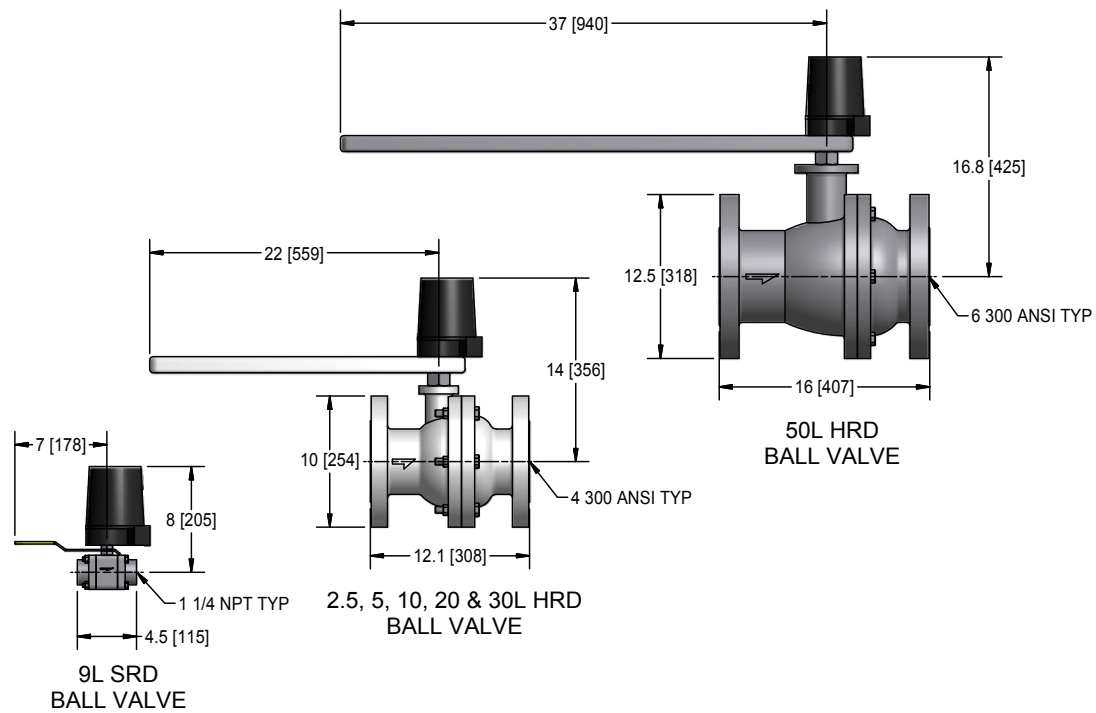

## ORDERING INFORMATION

Container Size	Ball Valve Kit P/N	Ball Valve Material	Pressure Rating psi (bar)	Spacer OAL (Approx) in (mm)	*Weight (Approx) lb (kg)
9L SRD	E80-0152	Carbon Steel	500 (34.5)	NA	12 (5.4)
9L SRD	E80-0153	Stainless Steel	500 (34.5)	NA	12 (5.4)
2.5, 5, 10L HRD	E80-035-04-01	Carbon Steel	740 (51.0)	NA	154 (69.9)
2.5, 5, 10L HRD	E80-036-04-01	Stainless Steel	720 (49.6)	NA	154 (69.9)
20L HRD	E80-035-04-20	Carbon Steel	740 (51.0)	1.9 (48)	154 (69.9)
20L HRD	E80-036-04-20	Stainless Steel	720 (49.6)	1.9 (48)	154 (69.9)
30L HRD	E80-035-04-30	Carbon Steel	740 (51.0)	4.8 (122)	154 (69.9)
30L HRD	E80-036-04-30	Stainless Steel	720 (49.6)	4.8 (122)	154 (69.9)
50L HRD	E80-035-06-50	Carbon Steel	740 (51.0)	2.9 (74)	279 (127)
50L HRD	E80-036-06-50	Stainless Steel	720 (49.6)	2.9 (74)	279 (127)

\* Included in weight; ball valve and proximity switch. Not included in weight; spacer, studs, nuts, gaskets or eyebolts.



Copyright © Fike Corporation All Rights Reserved.  
Form No. X.1.44.01 January, 2011 Specifications are subject to change without notice.